

2 PŁYTKI CERAMICZNE
CERAMIC TILES
KERAMIKFLIESEN



PERFECTION IN DETAILS
1958
since



Cezary Niewiński

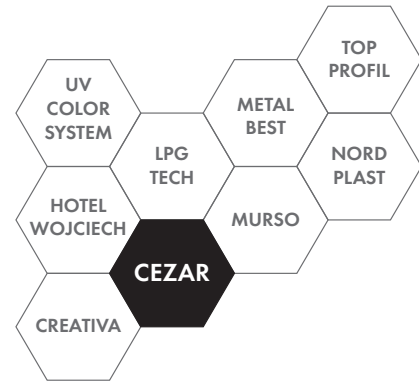

Od 1958 roku marka CEZAR jest synonimem najwyższej jakości, pionierskich innowacji i ponadczasowego wzornictwa. Założycielem firmy był genialny konstruktor Cezary Niewiński, którego zapał i duch odkrywcy można znaleźć w realizowanych projektach. Dziś Grupę CEZAR tworzy 8 firm, których główną działalnością jest wytwarzanie produktów do wykańczania wnętrz.

Since 1958, CEZAR brand has been synonymous with top quality, pioneering innovation and timeless design. The company was founded by Cezary Niewiński, a brilliant designer whose enthusiasm and explorer's spirit can still be found in the projects we complete. Today, CEZAR Group consists of 8 companies whose main activity is manufacture of products for interior finishing.

Seit 1958 steht die Marke CEZAR für höchste Qualität, bahnbrechende Innovation und zeitloses Design. Der Gründer des Unternehmens war der brillante Konstrukteur Cezary Niewinski, dessen Begeisterung und Entdeckergeist sich in den durchgeführten Projekten widerspiegelt. Heute besteht die Gruppe CEZAR aus 8 Unternehmen, deren Haupttätigkeit die Herstellung von Produkten für den Innenausbau ist.

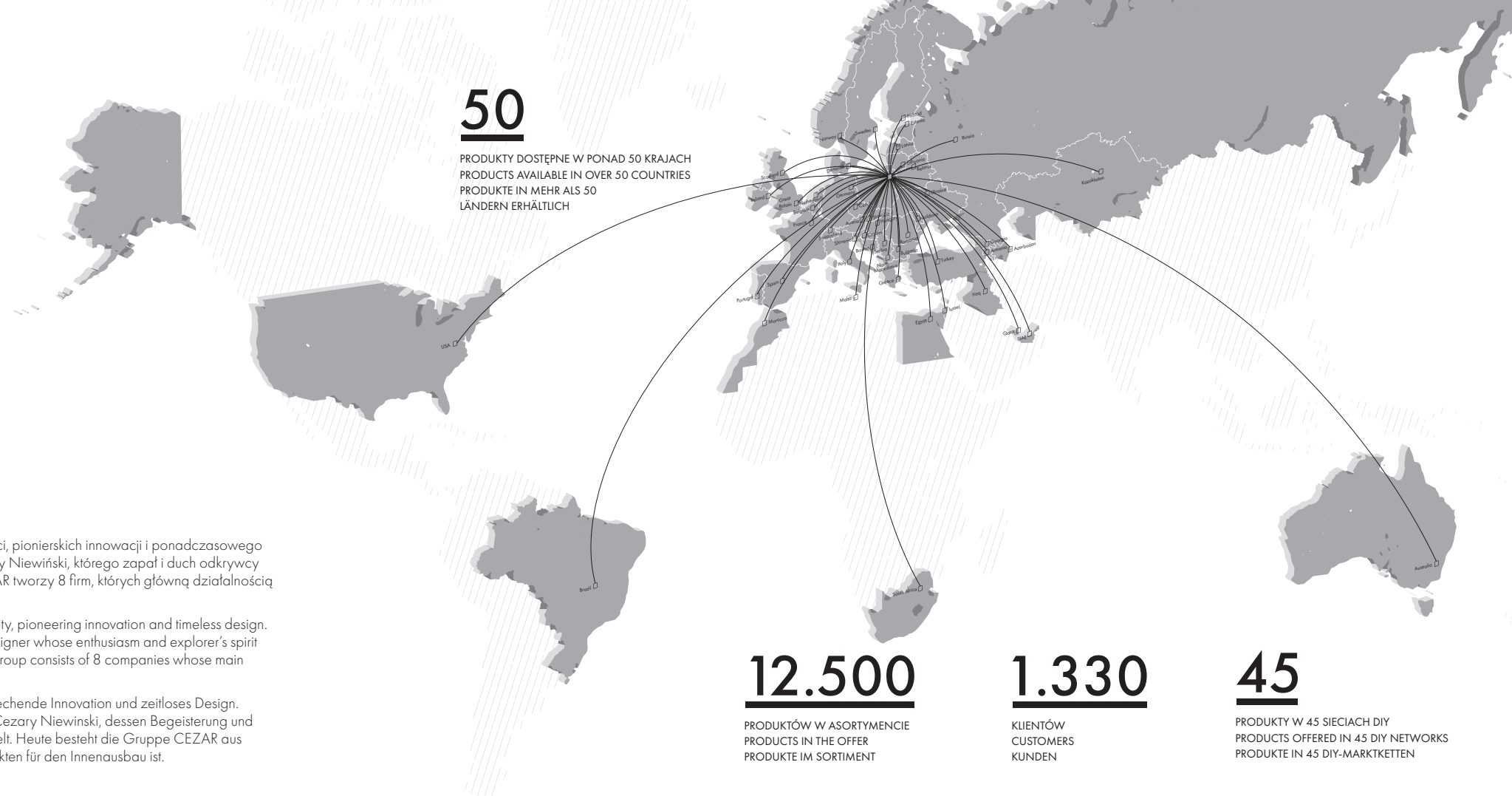

12.500
PRODUKTÓW W ASORTYMENCIE
PRODUCTS IN THE OFFER
PRODUKTE IM SORTIMENT

1.330
KLIENTÓW
CUSTOMERS
KUNDEN

45
PRODUKTY W 45 SIECIACH DIY
PRODUCTS OFFERED IN 45 DIY NETWORKS
PRODUKTE IN 45 DIY-MARKTKETTEN



6 FABRYK W ŚRODKU EUROPY
FACTORIES IN CENTRAL EUROPE
WERKE MITTEN IN EUROPA

Fabryki znajdujące się w niezależnych lokalizacjach zapewniają bezpieczeństwo w przypadku zdarzeń losowych.

The factories are located in independent locations to provide security in the event of unforeseen incidents.

Die Fabriken befinden sich an unabhängigen Standorten darum ihre Sicherheit ist gewährleistet bei zufälligen Ereignissen.



logistics

Centrum logistyczne o powierzchni 10.000 m² gwarantuje sprawną wysyłkę towarów. Logistykę na terenie Europy realizujemy własną flotą transportową.

Our 10.000 m² logistics centre guarantees efficient dispatch of goods. Logistics within Europe are handled by our own transport fleet.

Ein Logistikzentrum mit einer Fläche von 10.000 m² garantiert den effizienten Warenversand. Die Logistik innerhalb Europas Wir realisieren unsere besitzen eigen Transportflotte.



Wywodzimy się z Elku, jednego z najczystszych regionów Europy. Czujemy się odpowiedzialni za dziedzictwo przyrodnicze i przyszłość regionu. Tworzymy nasze produkty zgodnie z zasadami zrównoważonego rozwoju. Z biegiem lat udoskonalamy proces produkcji, zwiększając ilość składników mineralnych w produktach i zwiększamy wykorzystanie surowców z recyklingu.

We hail from Elk, a city located in one of the cleanest regions in Europe. We feel responsibility for the natural heritage and the future of the region. Our products are created in accordance with the principles of sustainability in mind. Over the years, we have been improving the production process, increasing the amount of minerals in the products and increasing the use of recycled raw materials.

Wir kommen aus Elk, einer der saubersten Regionen in Europa. Deshalb wir fühlen uns verantwortlich für Natur und die Zukunft der Region. Wir stellen unsere Produkte nach den Grundsätzen der Nachhaltigkeit her. Im Laufe der Jahre haben wir den Produktionsprozess verbessert, den Anteil an Mineralien in den Produkten erhöht und den Einsatz von recycelten Rohstoffen steigert.

design lab

Cezar od zawsze stawiał na innowacje. Design Lab to zespół designerów i konstruktorów projektujących nowe produkty oraz sposoby ich wytwarzania.

Cezar has always relied on innovation. Our Design Lab is a team of designers and developers who design new products and ways of making them.

Cezar hat schon immer auf Innovation gesetzt. Das Design Lab besteht aus einem Designern und Konstrukteure, das neue Produkte und Methoden zu ihrer Herstellung.

36.000

(m²) POWIERZCHNI MAGAZYNOWEJ
(m²) OF STORAGE SPACE
(m²) LAGERFLÄCHE



JAKOŚĆ POTWIERDZONA CERTYFIKATAMI
QUALITY PROVEN WITH CERTIFICATES
ZERTIFIZIERTE QUALITÄT



ZAPOZNAJ SIĘ Z OZNACZENIAMI W KATALOGU!
PLEASE SEE THE SYMBOLS IN THE CATALOGUE!
BEACHTEN SICH MIT MIT DIE SYMBOLEN DES KATALOGS!

WYMIARY I SPOSOBY MONTAŻU
DIMENSIONS AND ASSEMBLY INSTRUCTIONS
ERSETZUNG UND MONTAGEMETHODE

Wymiary
Dimensions
Maße

Max. grubość podłoża
Max. substrate thickness
Max. Untergrunddicke

Max. różnica poziomów
Max. level difference
Max. Bodenhöhenunterschied

- Profil do płytek ceramicznych
Fliesenprofil
- Profil do podłóg na tym samym poziomie
Profil für Böden auf gleicher Höhe
- Profil do podłóg z różnicą poziomów
Profil für Böden mit Höhenunterschied
- Profil schodowy
Treppenprofil
- Profil dla majsterkowicza lub budowlany
Profil für Heimwerker oder Bau

5in1 MONTAŻ UNIwersalny
UNIVERSAL INSTALLATION
UNIVERSELLE MONTAGE

MONTAŻ PODPŁYTKOWY
INSTALLATION UNDER TILES
UNTERFLIESEN MONTAGE

Natóż klej na podłożu oraz perforowaną część listwy./ Apply glue to the substrate and the perforated part of the trim./ Den Kleber auf den Untergrund und den perforierten Teil der Leiste auftragen.

Przyklej płytkę ceramiczną do podłoża wraz z profilem./ Install the ceramic tile to the substrate with the trim./ Die Keramikfliese mit dem Profil auf den Untergrund kleben.

Włóż pod profil panel./ Insert a panel under the profile./ Eine Platte unter dem Profil einsetzen.

MONTAŻ NA TRZPIEŃ WCISKANY CEZAR
CEZAR PRESS STUD INSTALLATION
MONTAGE MIT STECKBOLZEN „CEZAR“

Wywierć otwór w podłożu./ Drill a hole in the substrate./ Ein Loch in den Untergrund bohren.

Wsuń trzpień do prowadnicy w profilu./ Slide the plug into the guide in the profile./ Den Dübel unter Verwendung eines Holzklotzes einschlagen.

Wbij profil z kółkiem z użyciem drewnianego klocka./ Hammer down the profile with a plug using a wooden block./ Das Profil mit einem Dübel unter Verwendung eines Holzklotzes einschlagen.

MONTAŻ NA WKRĘT
SCREW INSTALLATION
SCHRAUBENMONTAGE

Przygotuj podłoże do montażu./ Prepare the substrate for installation./ Den Untergrund für die Montage vorbereiten.

Przyłóż profil do podłoża./ Place the profile to the substrate./ Das Profil auf dem Untergrund anbringen.

Przykręć profil do podłoża./ Screw down the profile to the substrate./ Das Profil mit dem Untergrund verschrauben.

MONTAŻ NA KLEJ
ADHESIVE INSTALLATION
KLEBEMONTAGE

Natóż klej montażowy z tyłu listwy./ Apply the assembly adhesive to the back of the trim./ Den Montagekleber auf der Rückseite der Leiste auftragen.

Odwróć listwę i przyłóż ją do podłoża./ Turn the trim over and apply it to the substrate./ Die Leiste umdrehen und auf den Untergrund legen.

Mocno dociśnij./ Press down firmly./ Fest andrücken.

MONTAŻ NA KLEJ NA LISTWIE
ADHESIVE INSTALLATION
KLEBEMONTAGE AUF LEISTE

Zdejmij papier zabezpieczający klej./ Remove the protective paper from the adhesive./ Das Schutzpapier des Klebers entfernen.

Odwróć profil i przyklej do podłoża./ Turn the profile over and stick it to the substrate./ Das Profil umdrehen und auf den Untergrund kleben.

Przyłóż profil do podłoża i mocno dociśnij./ Place the profile on the substrate and press down firmly./ Das Profil auf dem Untergrund anbringen und fest andrücken.

MONTAŻ NA DWUSTRONNĄ TAŚMĘ KLEJĄCĄ
INSTALLATION WITH DOUBLE-SIDED ADHESIVE TAPE
MONTAGE MIT DOPPELSEITIGEM KLEBBAND

Przyklej taśmę dwustronną do profilu i zdejmij papier./ Stick the double-sided tape to the profile and remove the protective paper./ Das doppelseitig Klebeband auf das Profil kleben und das Papier entfernen.

Odwróć profil i przyklej do podłoża./ Turn the profile over and stick it to the substrate./ Das Profil umdrehen und auf den Untergrund kleben.

Przyłóż profil do podłoża i mocno dociśnij./ Place the profile on the substrate and press down firmly./ Das Profil auf dem Untergrund anbringen und fest andrücken.

MONTAŻ NA WCISK
PRESS-FIT INSTALLATION
NUTMONTAGE

Dopasuj profil do szczeliny./ Align the profile with the slot. Das Profil in die Nut einpassen.

Wciśnij profil do szczeliny i mocno dociśnij./ Push the profile into the slot and press down firmly. /Das Profil in die Nut schieben und fest andrücken.

- AL** Aluminium
Aluminium
Aluminium
- PVC** Polichlorek winylu
Polyvinyl chloride
Polyvinylchlorid
- SN** Stal nierdzewna
Stainless steel
Edelstahl
- MS** Mosiądz
Brass
Messing
- AK** Akcesoria
Accessories
Zubehör
- MONTAŻ** Montaż
Assembly
Montage
- KOD QR** Kod QR - szczegółowa instrukcja montażu
QR code - detailed assembly instructions
QR-Code- ausführliche Montageanleitung
- UŻYTKOWANIE** Produkt do użytku wewnątrz i na zewnątrz
Product for indoor and outdoor use
Produkt für den Innen- und Außenbereich
- PROFIL OŚWIELENIOWY** Profil oświetleniowy
Lighting profile
Beleuchtungsprofil
- PROFIL OKAPOWY** Profil okapowy
Drip edge profile
Abtropfprofil
- PROFIL DO WYGINANIA** Profil do wyginania
A profile for bending
Biegeprofil
- KLASA ŚCIERALNOŚCI** Klasa ścieralności
Abrasion class
Abriebfestigkeitsklasse
- OGROZOWANIE** Do ogrzewania podłogowego
For underfloor heating
Für Fußbodenheizung

SYMBOLE LOGISTYCZNE
LOGISTICS SYMBOLS
LOGISTISCHE SYMBOLE

- Ilość w opakowaniu jednostkowym
Quantity per unit pack
Menge pro Packung
- Ilość w opakowaniu zbiorczym
Quantity per bulk package
Menge pro Sammelverpackung
- Ilość na paalecie
Pallet quantity
Anzahl pro Palette
- Kolor lub deseń produktu
Product colour or design
Produktfarbe oder - design
- Długość produktu
Product length
Produktlänge
- Wysokość produktu
Product height
Produkthöhe

EFEKT WYKOŃCZENIA PRODUKTÓW
TYPES OF PRODUCT FINISHES
VEREDELUNGSEFFEKT FÜR PRODUKTE



Produkt anodowany - matowy
 Anodised product - matt
 Eloxiertes Produkt - matt

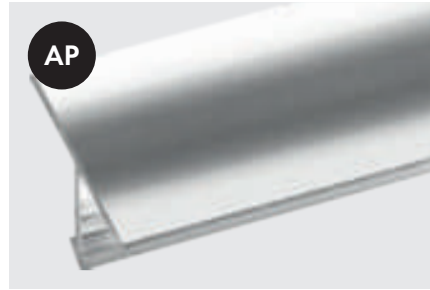

Produkt anodowany - polysk
 Anodised product - gloss
 Eloxiertes Produkt - glänzend

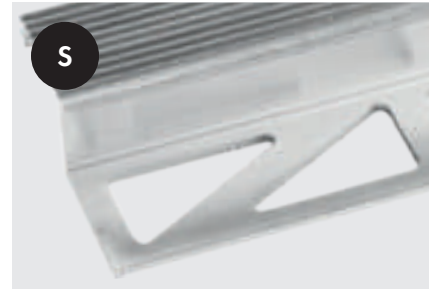

Wykończenie surowe
 Raw finish
 Rohe Oberfläche



Chrom polysk
 Chrome gloss
 Chrom glänzend



Stal nierdzewna naturalna
 Natural stainless steel
 Edelstahl natürlich

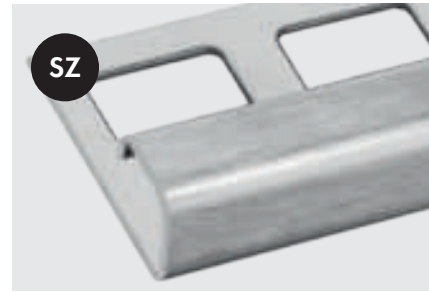

Stal nierdzewna szczotkowana
 Brushed stainless steel
 Edelstahl gebürstet



Polerowane aluminium lub miedz
 Polished aluminium or brass
 Poliertes Aluminium oder Messing



Malowanie proszkowe - polysk
 Powder coating - gloss
 Pulverbeschichtung - glänzend



Malowanie proszkowe - matowe
 Powder coating - matt
 Pulverbeschichtung - matt



Folia polysk
 Gloss foil
 Folie glänzend



Okleina mat
 Foil with wood finishes
 Folie mit Holzoptik



Produkt barwiony w masie - matowy
 Full body coloured product - matt
 Einfarbiges Produkt - matt

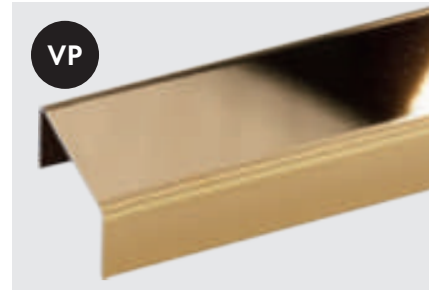

Wysoki polysk - stal nierdzewna
 Stainless steel - high gloss
 Hochglanz - Edelstahl

WARUNKI UŻYTKOWANIA PRODUKTÓW
CONDITIONS OF USE OF THE PRODUCTS
VERWENDUNGSBEDINGUNGEN FÜR DIE PRODUKTE

W trosce o Twoje zdrowie, bezpieczeństwo oraz długą żywotność produktów firmy Cezar przygotowaliśmy ogólne porady dotyczące montażu i użytkowania naszych wyrobów. W szczególności należy pamiętać, że:

- elementy wykończeniowe (listwy PVC, profile aluminiowe i mosiężne ze stali nierdzewnej) należy chronić przed zabrudzeniem materiałami mokrymi (beton, zaprawa, klej, fugi do płytek itp.) stosowanymi w przemyśle budowlanym, np.: w przypadku zabrudzenia należy niezwłocznie zmyć zanieczyszczenie czystą wodą,
- do przycinania profili metalowych nie stosować narzędzi mogących spowodować przegrzanie się materiału,
- do czyszczenia elementów metalowych nie należy stosować środków zawierających chlor lub inne substancje żrące,
- do montażu profili metalowych stosować tylko kleje montażowe i silikony neutralne chemicznie,
- do czyszczenia elementów z tworzyw sztucznych nie należy używać żadnych materiałów czyszczących zawierających rozpuszczalniki,
- elementy na których pozostały reszki etykiet, metek cenowych czy taśm należy zmyć szmatką nasączoną denaturatem,
- przed układaniem podkładów pod panele podłogowe posadzka powinna być oczyszczona i zabezpieczona przed wilgocią folią PE,
- do konserwacji podłóg drewnianych, drewnopochodnych, paneli ściennych oraz parapetów należy używać środków czyszczących przyjaznych dla środowiska naturalnego i nie wchodzących w reakcję z laminatem pokrywającym ich powierzchnię,
- do czyszczenia powierzchni trzeba stosować tkaninę o wysokim współczynniku pochłaniania wilgoci.

Pamiętaj, aby wszelkie prace budowlane były wykonywane przez wykwalifikowanych pracowników, którzy respektują przepisy prawa budowlanego. Producent nie ponosi odpowiedzialności za wyroby, które zostały użyte niezgodnie z przeznaczeniem, lub uległy uszkodzeniu w trakcie nieprawidłowego montażu.

- ! W czasie wykonywania pracy należy stosować się do ogólnych zasad bezpieczeństwa i higieny pracy. Uchroni to przed nieprzyjemnymi urazami oraz zapewni odpowiedni poziom bezpieczeństwa i pewny montaż!
- i Kolor wyrobu z różnych partii produkcyjnych może nieznacznie różnić się między sobą odcieniem.

For the sake of your health, safety and the long life of products by Cezar, we have prepared general advice on the installation and use of our products. In particular, remember the following:

- finishing elements (PVC strips, aluminium and brass stainless steel profiles) must be protected from contamination with wet materials, such as concrete, mortar, adhesive, tile grout, etc. used in the construction industry, for example in the event of contamination, the contamination must be washed off immediately with clean water,
- do not use tools that could overheat the material when cutting metal profiles,
- do not use agents containing chlorine or other corrosive substances to clean metal parts,
- use only chemically neutral mounting adhesives and silicones for installation of metal profiles,
- do not use any cleaning materials containing solvents to clean plastic parts,
- any parts with residues of labels, price tags or tapes should be washed off with a cloth soaked in denatured alcohol,
- the floor for laying laminate flooring underlay should be cleaned and protected against moisture with a PE film before laying the underlay,
- for maintenance of wooden and wood-based floors, wall panels and window sills, use environmentally friendly cleaning agents and do not react with the laminate flooring,
- use a fabric with a high moisture-absorbing capacity to clean the surface.

Remember to make sure that any construction work is carried out by qualified workers who respect building regulations. The manufacturer shall not be held liable for the products which have been used other than for their intended purpose or damaged during improper installation.

- ! Observe the general EHS rules when carrying out work. This could protect you from injuries and ensure adequate safety and secure installation!
- i The colour of the products from different production batches may vary slightly in shade.

Im Interesse Ihrer Gesundheit, Ihrer Sicherheit und der Langlebigkeit der Produkte von Cezar haben wir allgemeine Hinweise für die Montage und den Gebrauch unserer Produkte zusammengestellt. Dabei ist insbesondere Folgendes zu beachten:

- Veredelungselemente (PVC-Leisten, Aluminium- und Messingprofile aus rostfreiem Stahl) müssen vor Verunreinigung geschützt werden durch: Beton, Mörtel, Kleber, Fugenmörtel die in der Bauindustrie verwendet werden. Im Falle einer Verunreinigung muss diese sofort mit sauberem Wasser abgewaschen werden.
- Beim Schneiden von Metallprofilen keine Werkzeuge verwenden, die das Material überhitzen können,
- Chlorhaltige Mittel oder andere ätzende Stoffe sollten nicht zur Reinigung von Metallteilen verwendet werden.
- Für die Montage von Metallprofilen nur chemisch neutrale Montagekleber und Silikone verwenden.
- Zur Reinigung von Kunststoffteilen dürfen keine lösungsmittelhaltigen Reinigungsmittel verwendet werden.
- Eventuelle Rückstände von Etiketten, Preisschildern oder Klebebändern sollten mit einem in denaturiertem Alkohol getränkten Tuch abgewaschen werden.
- Der Boden sollte gereinigt und mit PE-Folie vor Feuchtigkeit geschützt werden, bevor die Unterlage für die Bodenplatten verlegt wird.
- Für die Pflege von Holz- und Holzwerkstoffböden, Wandplatten und Fensterbänken sind umweltfreundliche Reinigungsmittel zu verwenden, die nicht mit dem Laminat reagieren, das die Oberfläche bedeckt.
- Zur Reinigung der Oberfläche muss ein Gewebe mit hoher Feuchtigkeitsaufnahme-fähigkeit verwendet werden.

Achten Sie darauf, dass alle Bauarbeiten von qualifizierten Arbeitskräften ausgeführt werden, die die Bauvorschriften einhalten. Der Hersteller haftet nicht für Produkte, die nicht bestimmungsgemäß verwendet wurden oder bei unsachgemäßer Installation beschädigt wurden.

- ! Bei der Durchführung der Arbeiten müssen die allgemeinen Gesundheits- und Sicherheitsvorschriften eingehalten werden. So schützen Sie sich vor unangenehmen Verletzungen und sorgen für ausreichende Sicherheit und einen sicheren Einbau!
- i Die Farbe des Produkts aus verschiedenen Produktionschargen kann leicht variieren.

Profile krawędziowe
Edge profiles
Kantenprofile

26
PROFIL WEWNĘTRZNY SZEROKI
WIDE INNER TRIM
BREITE INNENLEISTE

10
LP

28
PROFIL OZDOBNY
DECORATIVE TRIM FOR TILES
DEKORATIVE LEISTE FÜR FLIESEN

Profile dylatacyjne
Expansion joint profiles
Dehnungsfugenprofile

Profile balkonowe
Balcony profiles
Balkonprofile

42
OKAP

11
L

29
W

34
DYS 85

43
OKAP 100

14
LK

30
WT

34
DY10G/ DY12G

15
PKOP

30
K 2525

35
DYW 10

Profile wannowe
Bathtub profiles
Wannenprofile

16
PKO

35
DY 10/ DY 20

44
PROFIL WANNOWY PODPLYTKOWY
UNDER-TILE BATHTUB PROFILE
UNTERFLIES-WANNENPROFIL

18
PKK/ N/ NQ

Profile ozdobne
Decorative profiles
Dekorative Profile

36
FUGA 5

44
PROFIL WANNOWY SAMOPRZYLEPNY
SELF-ADHESIVE BATHTUB PROFILE
SELBSTKLEBENDES WANNENPROFIL

20
PWP

31
DOW

36
FG 14/ 20

45
UO 13

21
ZW

31
DO 25

38
T 13/ 14/ 18/ 25/ 26

45
WNK

22
PROFIL ZEWNĘTRZNY
OUTER TRIM
AUSSENLEISTE

32
U

40
D 14P/ D 15P/ D 17P

24
ZZ 8

33
DU

Profile LED
LED profiles
LED-Profil

25
PROFIL WEWNĘTRZNY WĄSKI
NARROW INNER TRIM
SCHMALE INNENLEISTE

46
ALU LED

56
ZETOW/ ZETOW 12

62
LSS

Akcesoria montażowe
Installation accessories
Montagezubehör

56
CL

63
LSR

Profile progowe
Threshold profiles
Schwellenprofile

48
SYSTEM DO MONTAŻU PŁYTEK
SYSTEM FOR TILES INSTALLATION
SYSTEM ZUR FLIESENVERLEGUNG

57
Z3LVT/ Z5LVT

63
LSR 24

72
FIX LW 45

49
MULTISPACER

57
W3LVT/ W5LVT

64
LSR 36

72
FIX LW 50

50
KRZYŻYKI, KLINY, TRZPIENIE, ŁĄCZNIK
SPACERS, WEDGES, PINS, CONNECTOR
ABSTANDSHALTER, KEILE, STIFTE, VERBINDER

58
CL3LVT/ CL5LVT

64
LSSZG

73
ZET O FLEX

58
RYFL T23

65
LSS 44

73
OWAL

Profile schodowe
Staircase profiles
Treppenprofile

59
PODKG

65
LSSR

74
SKOS

52
PSP/ PSP 12

59
PODKZGCZ

66
LSW 10

75
SKOSR

53
ZET

60
20 P

68
LSW 20

52
ZETPL

61
20 R

70
KP

54
ZETPLP

61
30 R

Ekspozytory
Product displays
Produktpräsentation

55
PS 2

62
30 RR

76



LP

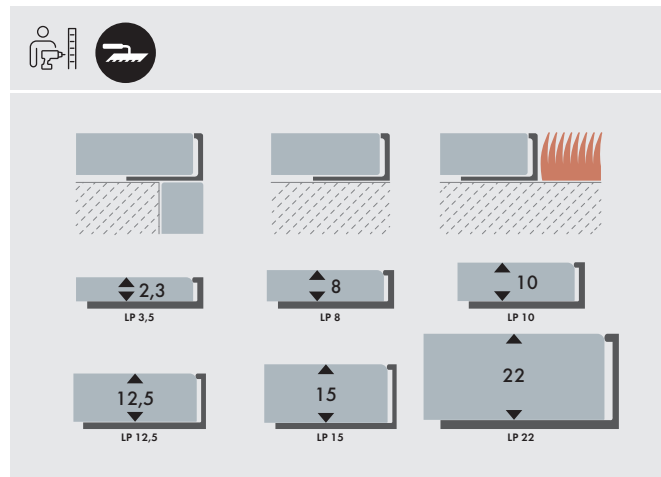

AL ALUMINIUM ANODOWANE
ANODIZED ALUMINIUM
ELOXIERTES ALUMINIUM

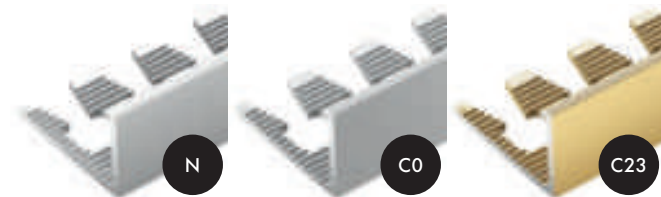

MS MOSIĄDZ
BRASS
MESSING



L 3,5	N	AL	S	2,5 m	826689**	10
	N	AL	S	1 m	801105**	10
L 8	N	AL	S	2,5 m	801136	10
	N	MS	S	1 m	811104***	10
	N	MS	S	2,5 m	811135**	10
	CO	AL	AM	2,5 m	801167	10
L 10	C23	AL	AM	2,5 m	801181**	10
	P	MS	SP	2,5 m	811272**	10
	N	AL	S	1 m	801204**	10
	N	AL	S	2 m	801228**	10
	N	AL	S	2,5 m	801235	10
	CO	AL	AM	2,5 m	801266	10
	C23	AL	AM	2,5 m	801280**	10
	CH	MS	CP	2 m	811265	10
L 12,5	N	MS	S	1 m	811203**	10
	N	MS	S	2 m	811227**	10
	N	MS	S	2,5 m	811234**	10
	P	MS	SP	2,5 m	816284**	10
	N	AL	S	1 m	801303**	10
	N	AL	S	2,5 m	801334	10
L 22	CO	AL	AM	2,5 m	801365	10
	C23	AL	AM	2,5 m	801389**	10
L 12,5	N	AL	S	2,5 m	801433	10
	N	AL	S	3 m	801440**	10
	CO	AL	AM	2,5 m	801464**	10
	N	AL	S	2,5 m	801532**	10
L 22	CO	AL	AM	2,5 m	801563**	10

** Na zamówienie/ Available on request/ Auf Anfrage verfügbar *** Outlet

L

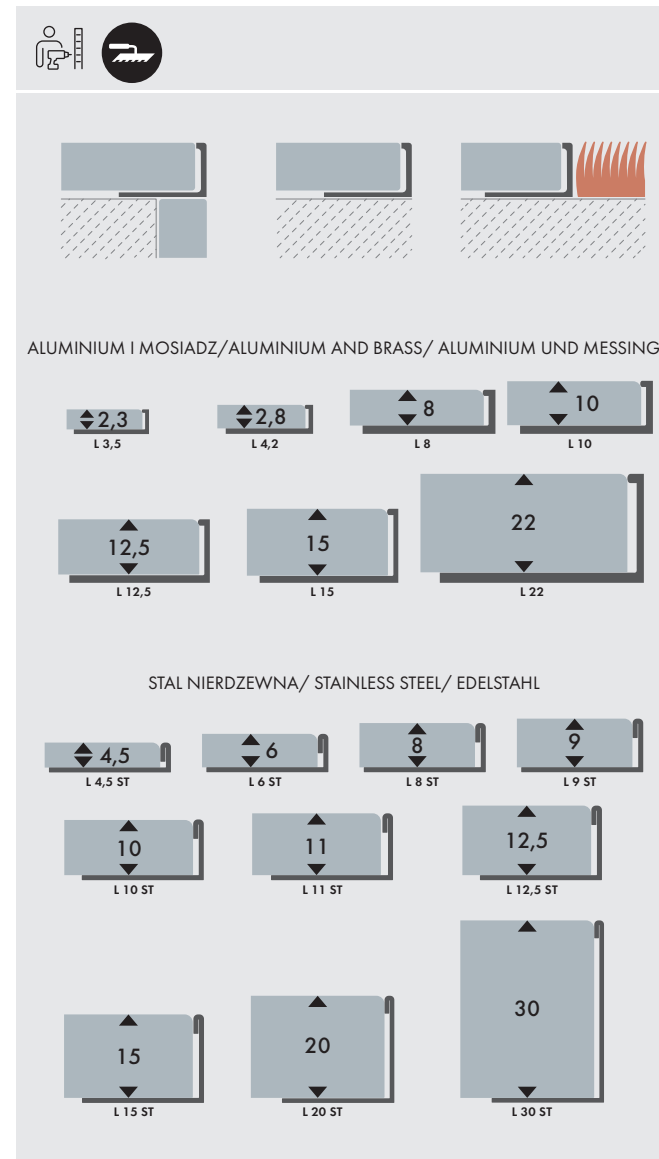

ALUMINIUM I MOSIĄDZ/ALUMINIUM AND BRASS/ ALUMINIUM UND MESSING

STAL NIERDZEWNA/ STAINLESS STEEL/ EDELSTAHL

(S) Wykończenie surowe/ Raw finish/ Rohe Oberfläche, (AM) Produkt anodowany - matowy/ Anodised product - matt/ Eloxiertes Produkt - matt, (SP) Polerowane aluminium lub mosiądz/ Polished aluminium or brass/ Poliertes Aluminium oder Messing, (CP) Chrom połysk/ Chrome gloss/ Chrom glänzend

L 3,5	N	AL	S	2,5 m	800061	10
L 4,2	N	AL	S	2,5 m	800139	10
	CO	AL	AM	2,5 m	800238**	10
L 4,5	N	SN	PB	2,5 m	819902**	10
L 6	N	AL	S	2,5 m	827495	10
	N	SN	PB	2,5 m	806476	10
	CO	AL	AM	2,5 m	827457	10
	ECO	AL	AP	2,5 m	800399**	10
	ECOS	AL	AP	2,5 m	806346	10
	P	AL	SP	2,5 m	806032	10
	N	AL	S	1 m	800306	10
	N	AL	S	2 m	800320	10
	N	AL	S	2,5 m	800337	10
	N	AL	S	3 m	800344	10
	CO	AL	AM	1 m	800351	10
	CO	AL	AM	2 m	806520	10
	CO	AL	AM	2,5 m	800368	10
	CO	AL	AM	3 m	806544	10
L 8	C32	AL	AM	2,5 m	806636	10
	C23	AL	AM	2,5 m	800382	10
	C33	AL	AM	2,5 m	806681**	10
	C34	AL	AM	2,5 m	805875**	10
	9005	AL	MM	2,5 m	824098	10
	9016	AL	MP	2,5 m	806704	10
	CH	MS	CP	2,5 m	827396	10
	CH	MS	CP	2,7 m	819636	10
	N	MS	S	2,5 m	810336**	10
	P	MS	SP	2,5 m	804922**	10
	P	MS	SP	2,7 m	821615	10
	N	SN	PB	1 m	897566	10
	N	SN	PB	2,5 m	897559	10
	SZ	SN	SZ	2,5 m	819933**	10

L 9	N	SN	PB	2,5 m	820021**	10
L 9	ECO	AL	AP	2,5 m	800467	10
	ECOS	AL	AP	2,5 m	806353	10
L 9	P	AL	SP	2,5 m	806124**	10
	P	AL	SP	2,5 m	806131	10
L 10	N	AL	S	1 m	800405	10
	N	AL	S	2 m	800429	10
	N	AL	S	2,5 m	800436	10
	N	AL	S	3 m	800443	10
	CO	AL	AM	1 m	800542	10
	CO	AL	AM	2 m	806827	10
	CO	AL	AM	2,5 m	800559	10
	CO	AL	AM	3 m	806841	10
	C32	AL	AM	2,5 m	806933	10
	C32	AL	AM	3 m	896163**	10
	C23	AL	AM	1 m	800566	10
	C23	AL	AM	2 m	806872**	10
	C23	AL	AM	2,5 m	800573	10
	C33	AL	AM	2,5 m	806988	10
L 10	C34	AL	AM	2,5 m	806995	10
	9016	AL	MP	2,5 m	800160	10
	1015	AL	MP	2,5 m	800177	10
	1001	AL	MP	2,5 m	800184	10
	1011	AL	MP	2,5 m	800214**	10
	7042	AL	MP	2,5 m	863240	10
	8024	AL	MP	2,5 m	800191	10
	8028	AL	MP	2,5 m	800207	10
	7024	AL	MP	2,5 m	840951*	10
	9005	AL	MP	2,5 m	824043	10
	9005	AL	MM	1 m	829017	10
	9005	AL	MM	2,5 m	824050	10
	CH	MS	CP	1 m	810503**	10

L 11	CH	MS	CP	2 m	810510	10	
	CH	MS	CP	2,5 m	860805	10	
	CH	MS	CP	2,7 m	819735	10	
	N	MS	S	1 m	810404**	10	
	N	MS	S	2 m	810428**	10	
	N	MS	S	2,5 m	810435	10	
	P	MS	SP	2,5 m	816130	10	
	P	MS	SP	2,7 m	819612**	10	
	N	SN	PB	1 m	897542	10	
	N	SN	PB	2,5 m	891496	10	
	SZ	SN	SZ	2,5 m	819766**	10	
	N	SN	PB	2,5 m	819773**	10	
	SZ	SN	SZ	2,5 m	819780**	10	
	L 11	ECO	AL	AP	2,5 m	800788	10
ECOS		AL	AP	2,5 m	806360	10	
P		AL	SP	2 m	863707**	10	
P		AL	SP	2,5 m	806230	10	
P		AL	SP	3 m	860270**	10	
N		AL	S	1 m	800603	10	
N		AL	S	2 m	800627	10	
N		AL	S	2,5 m	800634	10	
N		AL	S	3 m	800641	10	
L 12,5		CO	AL	AM	1 m	800665	10
		CO	AL	AM	2 m	807121	10
		CO	AL	AM	2,5 m	800658	10
		CO	AL	AM	3 m	807145	10
		C32	AL	AM	2,5 m	807107	10
	C23	AL	AM	1 m	800702	10	
	C23	AL	AM	2,5 m	800719	10	
	C33	AL	AM	2,5 m	807114**	10	
	C34	AL	AM	2,5 m	807138**	10	
	9016	AL	MP	2,5 m	806308	10	

L 15	1015	AL	MP	2,5 m	806315**	10		
	9005	AL	MM	1 m	829048	10		
	9005	AL	MM	2,5 m	824081	10		
	CH	MS	CP	2 m	810718**	10		
	CH	MS	CP	2,5 m	896422	10		
	CH	MS	CP	2,7 m	819629	10		
	N	MS	S	1 m	810602**	10		
	N	MS	S	2 m	810626**	10		
	N	MS	S	2,5 m	810633	10		
	P	MS	SP	2,5 m	816239	10		
	P	MS	SP	2,7 m	821844	10		
	N	SN	PB	1 m	897535	10		
	N	SN	PB	2,5 m	891502	10		
	SZ	SN	SZ	2,5 m	819797**	10		
L 15	P	AL	SP	2,5 m	895685**	10		
	N	AL	S	2 m	800825**	10		
	N	AL	S	2,5 m	800832	10		
	N	AL	S	3 m	800849**	10		
	N	SN	PB	2,5 m	806452**	10		
	CO	AL	AM	2,5 m	800931	10		
	CO	AL	AM	3 m	865442**	10		
	L 20	N	SN	PB	2,5 m	806469	10	
		N	AL	S	1 m	801006**	10	
		N	AL	S	2 m	801020**	10	
		L 22	N	AL	S	2,5 m	801037	10
			N	MS	S	1 m	811005***	10
			CO	AL	AM	2,5 m	801068	10
			C33	AL	AM	2,5 m	898631**	10
L 30			N	SN	PB	2,5 m	819889**	10

** Na zamówienie/ Available on request/ Auf Anfrage verfügbar *** Outlet

AL ALUMINIUM ANODOWANE
ANODIZED ALUMINIUM
ELOXIERTES ALUMINIUM

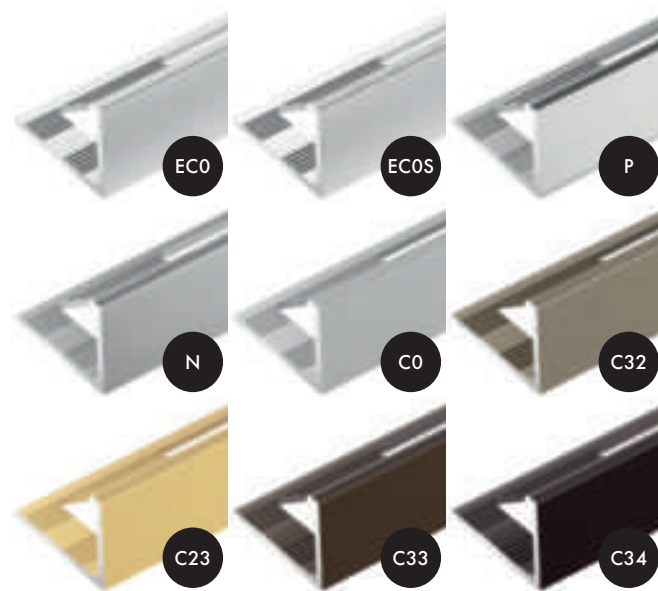

MS MOSIĄDZ
BRASS
MESSING

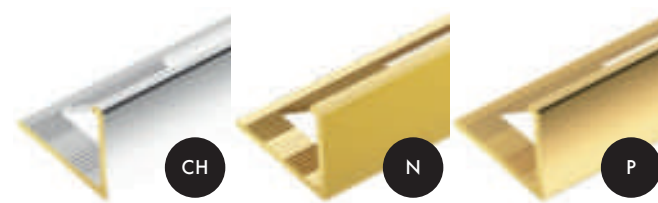

SN STAL NIERDZEWNIA
STAINLESS STEEL
EDELSTAHL

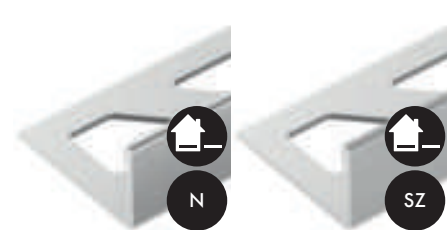

AM ALUMINIUM MALOWANE PROSZKOWO
POWDER-COATED ALUMINIUM
PULVERBESCHICHTETES ALUMINIUM

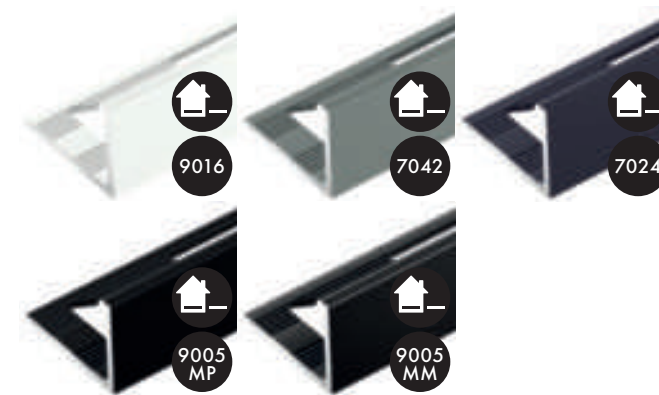

[S] Wykończenie surowe/ Raw finish/ Rohe Oberfläche, [AM] Produkt anodowany - matowy/ Anodised product - matt/ Eloxiertes Produkt - matt, [PB] Stal nierdzewna naturalna/ Natural stainless steel/ Edelstahl natürlich, [SP] Polerowane aluminium lub mosiądz/ Polished aluminium or brass/ Poliertes Aluminium oder Messing, [MM] Malowanie proszkowe - matowe/ Powder coating - matt/ Pulverbeschichtung - matt, [CP] Chrom polysk/ Chrome gloss/ Chrom glänzend, [MP] Malowanie proszkowe - polysk/ Powder coating - gloss/ Pulverbeschichtung - glänzend, [SZ] Stal nierdzewna szczotkowana/ Brushed stainless steel/ Edelstahl gebürstet

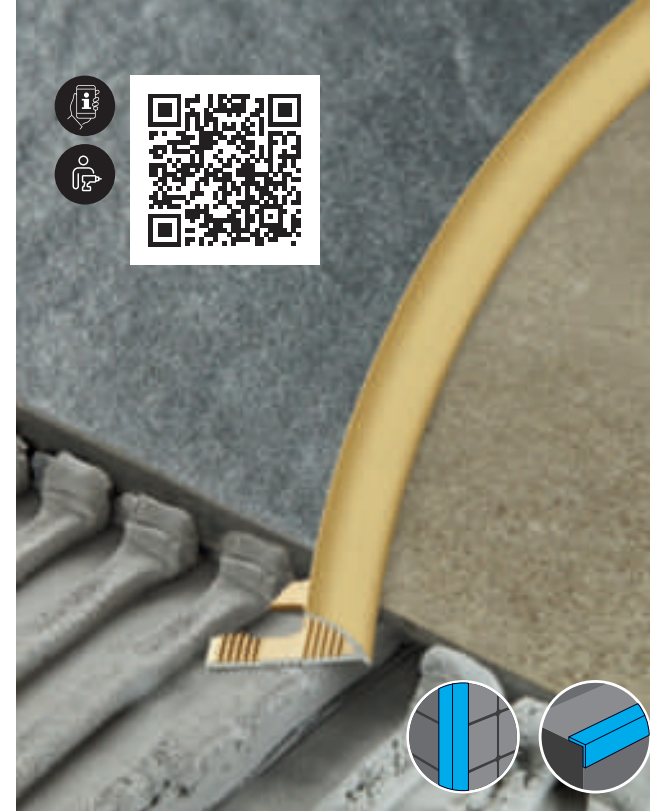

Ø 6P	C23	AL	AM	2,5 m	862687***	10
Ø 8P	CO	AL	AM	2,5 m	863134	10
	C23	AL	AM	2,5 m	863189**	10
Ø 10P	P	AL	SP	2,5 m	802331	10
	N	AL	S	2 m	802720**	10
	N	AL	S	2,5 m	802737**	10
	CO	AL	AM	2,5 m	802768	10
	C23	AL	AM	2,5 m	802782**	10
Ø 12P	N	MS	S	1 m	812705***	10
	P	MS	SP	2,5 m	812330**	10
	CO	AL	AM	2,5 m	863639**	10
	C23	AL	AM	2,5 m	863684**	10
	CH	MS	CP	2,5 m	824197*	10
	P	MS	SP	2,5 m	892264**	10

** Na zamówienie/ Available on request/ Auf Anfrage verfügbar *** Outlet

LK

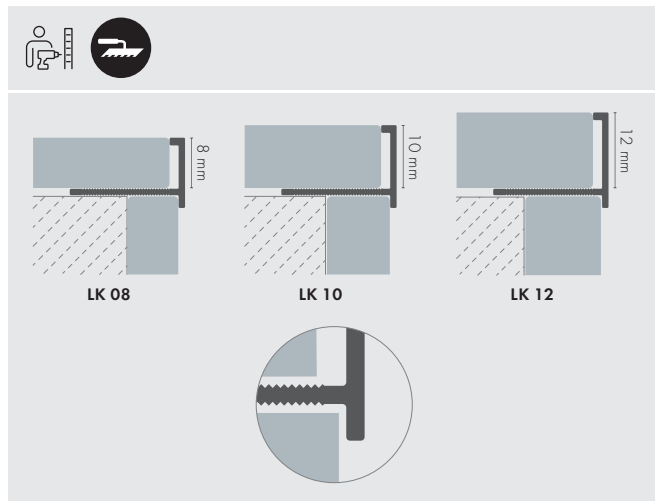

AL ALUMINIUM ANODOWANE
ANODIZED ALUMINIUM
ELOXIERTES ALUMINIUM

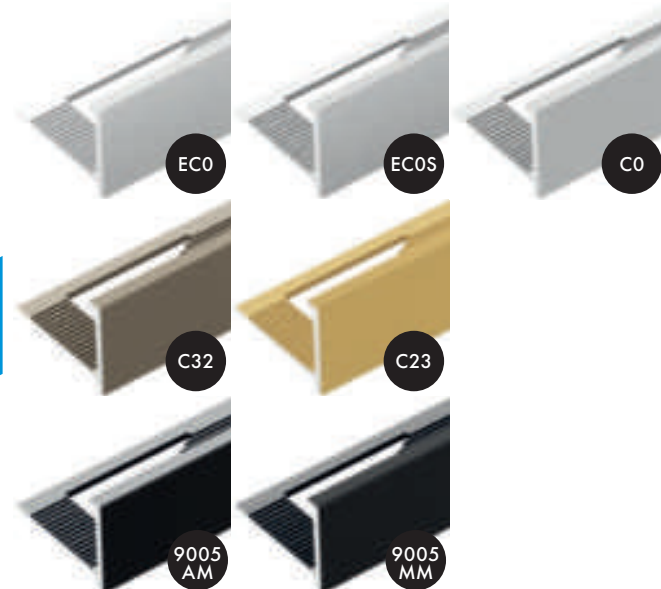

LK08	ECO	AL	AP	2,5 m	825132	10
	CO	AL	AM	2,5 m	825101	10
	ECOS	AL	AP	2,5 m	825149**	10
	C32	AL	AM	2,5 m	825125**	10
	C23	AL	AM	2,5 m	825118**	10
	9005	AL	AM	2,5 m	825095**	10
LK10	9005	AL	MM	2,5 m	825088	10
	ECO	AL	AP	2,5 m	825200	10
	ECOS	AL	AP	2,5 m	825217	10
	CO	AL	AM	2,5 m	825170	10
	C32	AL	AM	2,5 m	825194	10
	C23	AL	AM	2,5 m	825187	10
LK12	9005	AL	AM	2,5 m	825163	10
	9005	AL	MM	2,5 m	825156	10
	ECO	AL	AP	2,5 m	825279	10
	ECOS	AL	AP	2,5 m	825286**	10
	CO	AL	AM	2,5 m	825248	10
	C32	AL	AM	2,5 m	825262	10
LK12	C23	AL	AM	2,5 m	825255**	10
	9005	AL	AM	2,5 m	825231	10
	9005	AL	MM	2,5 m	825224	10

** Na zamówienie/ Available on request/ Auf Anfrage verfügbar

PKOP

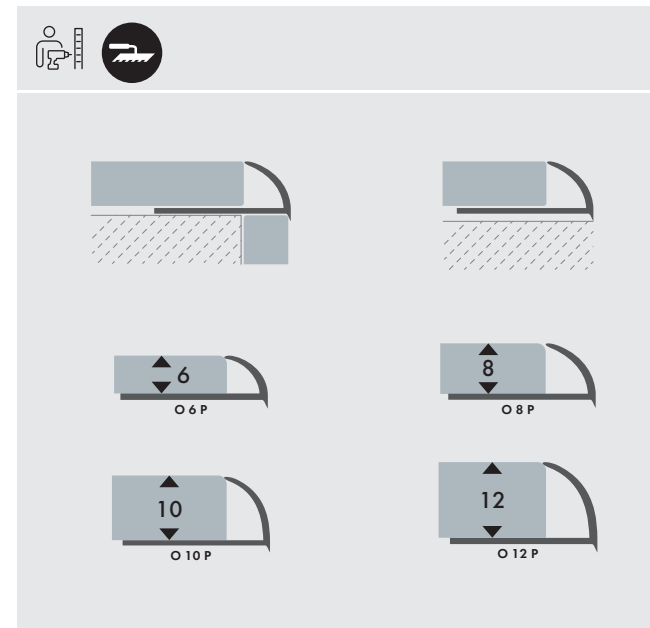

Akcesoria/ Accessories/ Zubehör

Ø 8	ECO	AL	AP	810046***	150
	CO	AL	AM	809996**	150
Ø 10	ECO	AL	AP	810008**	150
	ECOS	AL	AP	809989**	150

** Na zamówienie/ Available on request/ Auf Anfrage verfügbar *** Outlet

AL ALUMINIUM ANODOWANE
ANODIZED ALUMINIUM
ELOXIERTES ALUMINIUM

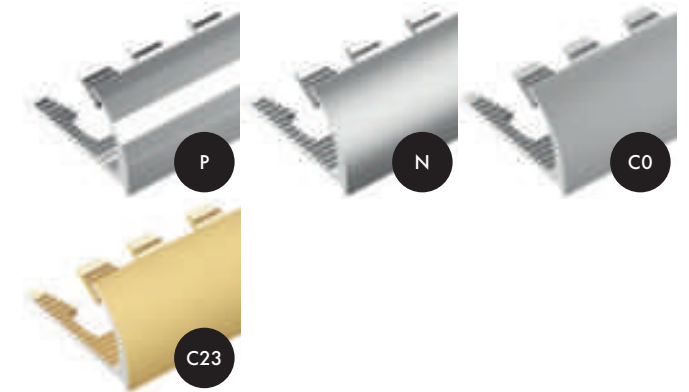

MS MOSIĄDZ
BRASS
MESSING

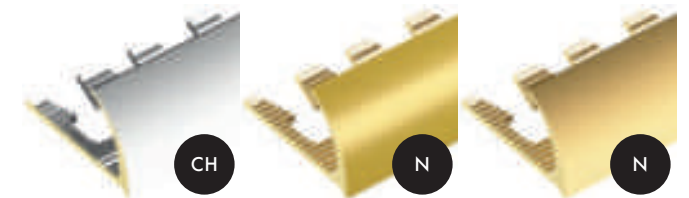

AL ALUMINIUM ANODOWANE
ANODIZED ALUMINIUM
ELOXIERTES ALUMINIUM





PKO



ALUMINIUM I MOSIADZ/ALUMINIUM AND BRASS/ ALUMINIUM UND MESSING



STAL NIERDZEWNA/ STAINLESS STEEL/ EDELSTAHL



AL Akcesoria/ Accessories/ Zubehör

	ECO	AL	AP	810046***	2	150
O 8	ECO	AL	AP	810046***	2	150
	CO	AL	AM	809996**	2	150
O 10	ECO	AL	AP	810008**	2	150
	ECOS	AL	AP	809989**	2	150

** Na zamówienie/ Available on request/ Auf Anfrage verfügbar *** Outlet

AL ALUMINIUM ANODOWANE ANODIZED ALUMINIUM ELOXIERTES ALUMINIUM



SN Akcesoria/ Accessories/ Zubehör

	SZ	SN	SZ	809897	2	150
O 10 SN	SZ	SN	SZ	809897	2	150
	PB	SN	N	809903	2	150
O 12 SN	SZ	SN	SZ	809910	2	150

SN STAL NIERDZEWNA STAINLESS STEEL EDELSTAHL



	N	SN	PB	2,5 m	809552	10
O 6	N	SN	PB	2,5 m	809552	10
	C23	AL	AM	2,5 m	842689***	10
	P	AL	SP	2,5 m	843082	10
	N	AL	S	1 m	860874**	10
	N	AL	S	2,5 m	843037	10
	CO	AL	AM	1 m	860867**	10
	CO	AL	AM	2,5 m	843136	10
O 8	C32	AL	AM	2,5 m	896125**	10
	C23	AL	AM	2,5 m	843181	10
	9016	AL	MP	2,5 m	807510**	10
	N	SN	PB	1 m	860881	10
	N	SN	PB	2,5 m	895944	10
	SZ	SN	SZ	2,5 m	820359	10
	ECO	AL	AP	2,5 m	802355	10
	ECOS	AL	AP	2,5 m	828393	10
	P	AL	SP	2 m	802126**	10
	P	AL	SP	2,5 m	802133	10
	N	AL	S	1 m	802003**	10
	N	AL	S	2 m	802027	10
	N	AL	S	2,5 m	802034	10
	N	AL	S	3 m	802041	10
	CO	AL	AM	1 m	802249	10
	CO	AL	AM	2 m	805721	10
	CO	AL	AM	2,5 m	802256	10
	CO	AL	AM	3 m	805745**	10
	C32	AL	AM	2,5 m	802287	10
	C23	AL	AM	1 m	802263**	10
O 10	C23	AL	AM	2,5 m	802270	10
	EC23	AL	AP	2,5 m	802379**	10
	C33	AL	AM	2,5 m	802294**	10
	C34	AL	AM	2,5 m	802362**	10
	9016	AL	MP	2,5 m	802164	10
	1015	AL	MP	2,5 m	802171**	10
	9005	AL	MM	2,5 m	824111	10
	CH	MS	CP	2 m	812217	10
	CH	MS	CP	2,7 m	810183**	10
	N	MS	S	1 m	812002**	10
	N	MS	S	2 m	812026**	10
	N	MS	S	2,5 m	812033	10
	P	MS	SP	2,5 m	812132**	10
	N	SN	PB	1 m	860898	10
	N	SN	PB	2,5 m	891533	10
	SZ	SN	SZ	2,5 m	820274**	10

** Na zamówienie/ Available on request/ Auf Anfrage verfügbar *** Outlet

SN STAL NIERDZEWNA STAINLESS STEEL EDELSTAHL

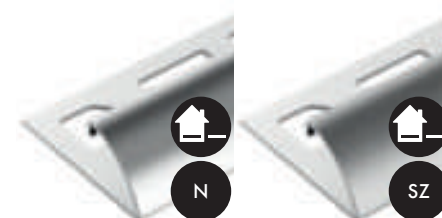

	ECO	AL	AP	2,5 m	807503**	10
	ECO	AL	AP	2,5 m	807503**	10
	P	AL	SP	2,5 m	843587	10
	N	AL	S	1 m	860911**	10
	N	AL	S	2,5 m	843532	10
	CO	AL	AM	1 m	860904**	10
O 12	CO	AL	AM	2,5 m	843631	10
	C32	AL	AM	2,5 m	843648	10
	C23	AL	AM	2,5 m	843686	10
	CH	MS	CP	2,5 m	824180**	10
	N	MS	S	2,5 m	812057**	10
	P	MS	SP	2,5 m	812064**	10
	P	MS	SP	2,7 m	821967**	10
O 12,5	N	SN	PB	1 m	860928**	10
	N	SN	PB	2,5 m	891540	10
	SZ	SN	SZ	2,5 m	820281**	10

AL ALUMINIUM ANODOWANE ANODIZED ALUMINIUM ELOXIERTES ALUMINIUM

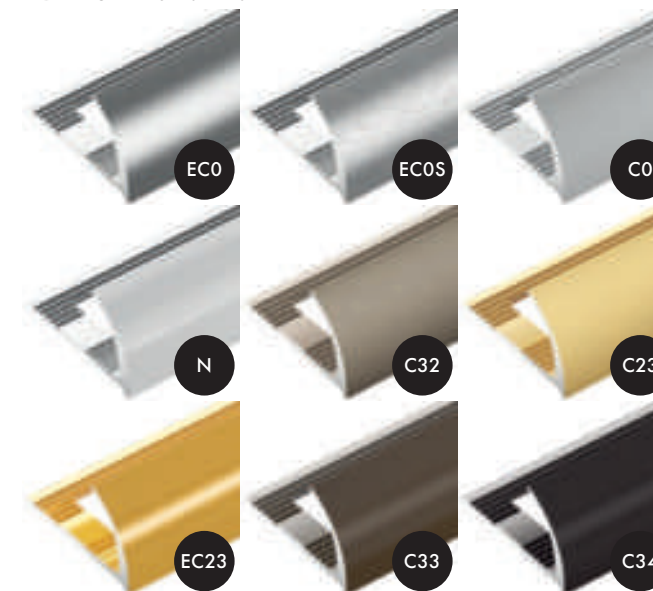

AL ALUMINIUM MALOWANE PROSZKOWO POWDER-COATED ALUMINIUM PULVERBESCHICHTETES ALUMINIUM



MS MOSIADZ BRASS MESSING

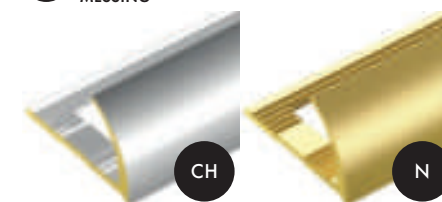

(PB) Stal nierdżewna naturalna/ Natural stainless steel/ Edelstahl natürlich, (AM) Produkt anodowany - matowy/ Anodised product - matt/ Eloxiertes Produkt - matt, (SP) Polerowane aluminium lub mosiądz/ Polished aluminium or brass/ Poliertes Aluminium oder Messing, (S) Wykonczenie surowe/ Raw finish/ Rohe Oberfläche, (MP) Malowanie proszkowe - polysk/ Powder coating - gloss/ Pulverbeschichtung - glänzend, (PB) Stal nierdżewna naturalna/ Natural stainless steel/ Edelstahl natürlich, (SZ) Stal nierdżewna szczotkowana/ Brushed stainless steel/ Edelstahl gebürstet, (CP) Chrom polysk/ Chrome gloss/ Chrom glänzend, (AP) Produkt anodowany - polysk/ Anodised product - gloss/ Eloxiertes Produkt - glänzend



PKK/ N/ NQ

Profile krawędziowe/ Edge profiles/ Kantenprofile

ALUMINIUM I MOSIADZ/ALUMINIUM AND BRASS/ ALUMINIUM UND MESSING

PKK 0908	8 mm	10 mm
PKK 0910	10 mm	10 mm
PKK 1008	8 mm	11 mm
PKK 1108	8 mm	12 mm

STAL NIERDZEWNA/ STAINLESS STEEL/ EDELSTAHL

N 9 ST	8 mm	8 mm
N 11 ST	8 mm	11 mm
NQ 9 ST	9 mm	9 mm
NQ 10 ST	10 mm	10 mm
NQ 11 ST	11 mm	11 mm



EC44	AL	AP	2,5 m	807015	10		
CO	AL	AM	2,5 m	862885	10		
C41	AL	AM	2,5 m	806957	10		
C41S	AL	AM	2,5 m	806964	10		
PKK 0908	EC43S	AL	AP	2,5 m	807022	10	
	EC35	AL	AP	2,5 m	806971	10	
	EC35S	AL	AP	2,5 m	807008	10	
	CH	MS	CP	2,5 m	862984	10	
	P	MS	SP	2,5 m	820458**	10	
PKK 0910	ECO	AL	AP	2,5 m	862878**	10	
	EC32S	AL	AP	2,5 m	862892	10	
	CO	AL	AP	2,5 m	821585	10	
	CO	AL	AM	2,5 m	862908	10	
	EC44	AL	AP	2,5 m	807077	10	
	C41	AL	AM	2,5 m	807039	10	
PKK 1008	C41S	AL	AM	2,5 m	807046	10	
	EC43S	AL	AP	2,5 m	807084	10	
	EC35	AL	AP	2,5 m	807053	10	
	EC35S	AL	AP	2,5 m	807060	10	
	CH	MS	CP	2,5 m	862991	10	
	ECO	AL	AP	2,5 m	821592	10	
	ECO	AL	AP	2,5 m	862915**	10	
	ECO	AL	AP	2,5 m	809958**	150	
	ECOS	AL	AP	2,5 m	862922	10	
PKK 1212	EC44	AL	AP	2,5 m	807206	10	
	C41	AL	AM	2,5 m	807091	10	
	C41S	AL	AM	2,5 m	807152	10	
	EC43S	AL	AP	2,5 m	807213	10	
	EC32S	AL	AP	2,5 m	862939	10	
	EC35	AL	AP	2,5 m	807169	10	
	EC35S	AL	AP	2,5 m	807183	10	
	N 9	N	SN	PB	2,5 m	891557	10
	N 11	N	SN	PB	2,5 m	820045**	10
	NQ 9	N	SN	PB	2,5 m	820212**	10
	NQ 10	N	SN	PB	2,5 m	820083	10
		SZ	SN	SZ	2,5 m	820090**	10
	NQ 11	N	SN	PB	2,5 m	820113***	10

** Na zamówienie/ Available on request/ Auf Anfrage verfügbar *** Outlet

AL ALUMINIUM ANODOWANE
ANODIZED ALUMINIUM
ELOXIERTES ALUMINIUM



MS MOSIADZ
BRASS
MESSING

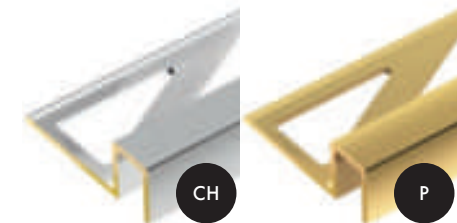

SN STAL NIERDZEWNA
STAINLESS STEEL
EDELSTAHL

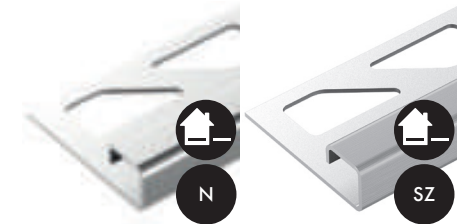

Aksesoria/ Accessories/ Zubehör



AL ALUMINIUM ANODOWANE
ANODIZED ALUMINIUM
ELOXIERTES ALUMINIUM

PKK 1008	ECO	AL	AP	809958**	150
----------	-----	----	----	----------	-----

** Na zamówienie/ Available on request/ Auf Anfrage verfügbar

(AP) Produkt anodowany - połysk/ Anodised product - gloss/ Eloxiertes Produkt - glänzend, (AM) Produkt anodowany - matowy/ Anodised product - matt/ Eloxiertes Produkt - matt, (CP) Chrom połysk/ Chrome gloss/ Chrom glänzend, (SP) Polerowane aluminium lub mosiądz/ Polished aluminium or brass/ Poliertes Aluminium oder Messing, (PB) Stal nierdzewna naturalna/ Natural stainless steel/ Edelstahl natürlich, (SZ) Stal nierdzewna szczotkowana/ Brushed stainless steel/ Edelstahl gebürstet

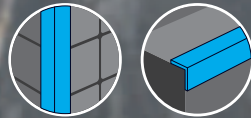

PWP

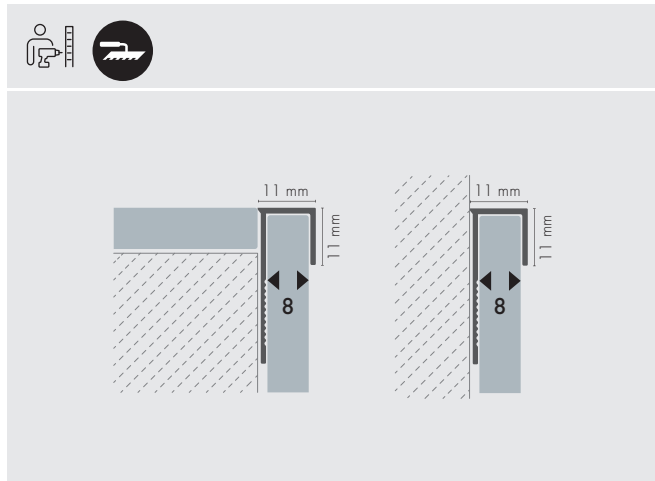

AL ALUMINIUM ANODOWANE
ANODIZED ALUMINIUM
ELOXIERTES ALUMINIUM

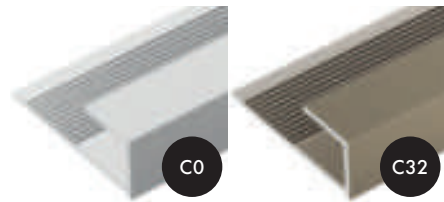

AL ALUMINIUM MALOWANE PROSZKOWO
POWDER-COATED ALUMINIUM
PULVERBESCHICHTETES ALUMINIUM



PWP 08	C0	AL	AM	2,5 m	825514**	10
	C32	AL	AM	2,5 m	825521***	10
	9005	AL	MM	2,5 m	825507**	10

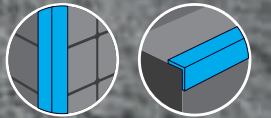

ZW

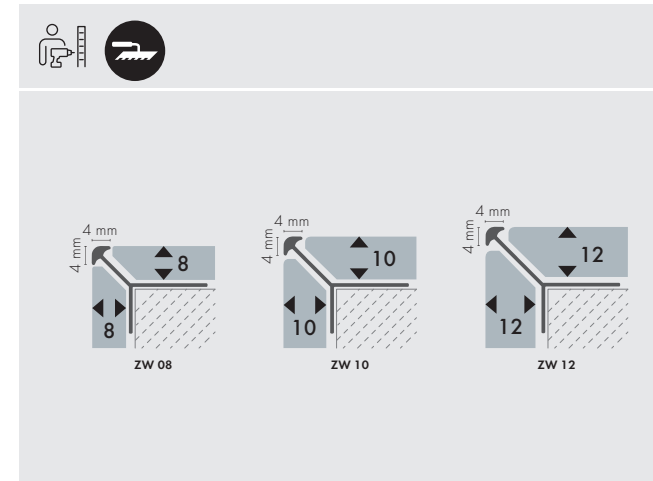

ZW08	ECO	AL	AP	2,5 m	821738	10
	C0	AL	AM	2,5 m	821691	10
	C23	AL	AM	2,5 m	821714	10
ZW10	EC23	AL	AP	2,5 m	821783	10
	C50	AL	AM	2,5 m	821776	10
	ECO	AL	AP	2,5 m	821653	10
ZW12	C0	AL	AM	2,5 m	821639	10
	C23	AL	AM	2,5 m	821646	10
	EC23	AL	AP	2,5 m	821752	10
	C50	AL	AM	2,5 m	821769	10
	ECO	AL	AP	2,5 m	821684	10
	C0	AL	AM	2,5 m	821660	10
	C23	AL	AM	2,5 m	821677	10
	EC23	AL	AP	2,5 m	821745	10
	C50	AL	AM	2,5 m	821790	10

AL ALUMINIUM ANODOWANE
ANODIZED ALUMINIUM
ELOXIERTES ALUMINIUM

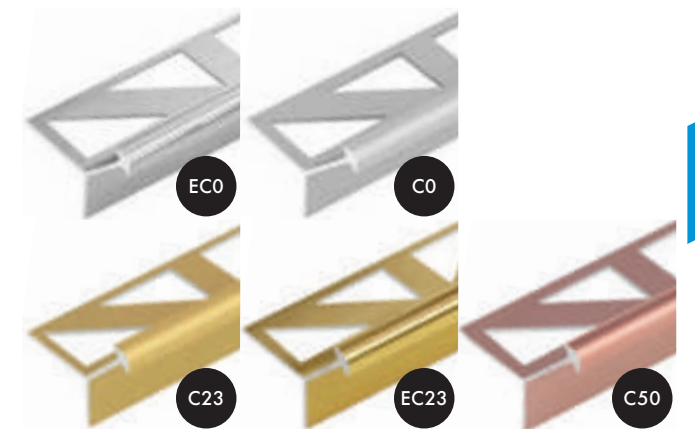



**PROFIL ZEWNĘTRZNY
OUTER TRIM
AUSSENLEISTE**

PVC

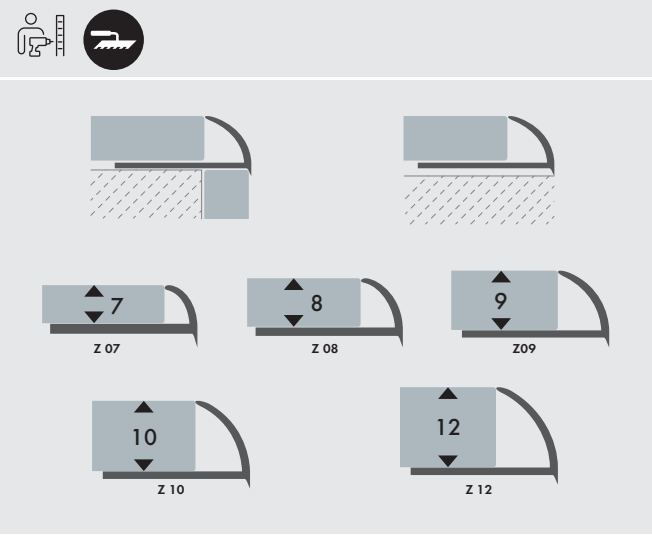

Akcesoria/ Accessories/ Zubehör

Z08	1001	PS	BM	636394	150
	105	PS	BM	637674	150
	184	PS	BM	637681**	150
Z10	1015	PS	BM	636363	150
	184	PS	BM	636370	150

** Na zamówienie/ On request/ Auf Anfrage



(BM) Produkt barwiony w masie - matowy/ Full body coloured product - matt/ Einfarbiges Produkt - matt, **(FP)** Folia polysk/ Gloss foil/ Folie glänzend

Z 07	1001	PC	BM	2,5 m	607035	90	
	1011	PC	BM	2,5 m	607332**	90	
	1015	PC	BM	2,5 m	607028	90	
	105	PC	BM	2,5 m	607059	90	
	107	PC	BM	2,5 m	607073	90	
	119	PC	BM	2,5 m	607196**	90	
	120	PC	BM	2,5 m	607202**	90	
	125	PC	BM	2,5 m	607257	90	
	136	PC	BM	2,5 m	607363**	90	
	138	PC	BM	2,5 m	607387**	90	
	202	PC	FP	2,5 m	608025**	90	
	213	PC	FP	2,5 m	608131	90	
	7037	PC	BM	2,5 m	607066	90	
	8019	PC	BM	2,5 m	607172**	90	
	8024	PC	BM	2,5 m	607103**	90	
	8028	PC	BM	2,5 m	607141**	90	
	9003	PC	BM	2,5 m	607011	90	
	9005	PC	BM	2,5 m	607134**	90	
	Z 08	1001	PC	BM	2,5 m	611032	90
		1011	PC	BM	2,5 m	611339	90
1015		PC	BM	2,5 m	611025	90	
105		PC	BM	2,5 m	611056	90	
107		PC	BM	2,5 m	611070	90	
119		PC	BM	2,5 m	611193	90	
120		PC	BM	2,5 m	611209**	90	
125		PC	BM	2,5 m	611254	90	
136		PC	BM	2,5 m	611360**	90	
138		PC	BM	2,5 m	611384**	90	
201		PC	FP	2,5 m	612015**	90	
202		PC	FP	2,5 m	612022**	90	
203		PC	FP	2,5 m	612039**	90	
213		PC	FP	2,5 m	612138	90	
217		PC	FP	2,5 m	612176**	90	
7037		PC	BM	2,5 m	611063	90	
8019		PC	BM	2,5 m	611179	90	
8024		PC	BM	2,5 m	611100**	90	
8028		PC	BM	2,5 m	611148**	90	
9003		PC	BM	2,5 m	611018	90	
9005	PC	BM	2,5 m	611131	90		
Z 09	1001	PC	BM	2,5 m	615030	80	
	1011	PC	BM	2,5 m	615337	80	
	1015	PC	BM	2,5 m	615023	80	
	105	PC	BM	2,5 m	615054	80	
	107	PC	BM	2,5 m	615078	80	
	119	PC	BM	2,5 m	615191	80	
	120	PC	BM	2,5 m	615207**	80	
	125	PC	BM	2,5 m	615252	80	
	136	PC	BM	2,5 m	615368**	80	
	138	PC	BM	2,5 m	615382**	80	
	201	PC	FP	2,5 m	616013**	80	
	202	PC	FP	2,5 m	616020	80	

Z 09	203	PC	FP	2,5 m	616037	80
	206	PC	FP	2,5 m	616068**	80
	213	PC	FP	2,5 m	616136	80
	216	PC	FP	2,5 m	616167	80
	224	PC	FP	2,5 m	618246**	80
	230	PC	FP	2,5 m	618307**	80
	7037	PC	BM	2,5 m	615061	80
	8019	PC	BM	2,5 m	615177	80
	8024	PC	BM	2,5 m	615108	80
	8028	PC	BM	2,5 m	615146	80
	9003	PC	BM	2,5 m	615016	80
	9005	PC	BM	2,5 m	615139	80
	1001	PC	BM	2,5 m	623035	80
	1011	PC	BM	2,5 m	623332	80
	1015	PC	BM	2,5 m	623028	80
	105	PC	BM	2,5 m	623059	80
	107	PC	BM	2,5 m	623073	80
	119	PC	BM	2,5 m	623196	80
	125	PC	BM	2,5 m	623257	80
	138	PC	BM	2,5 m	623387**	80
184	PC	BM	2,5 m	640131	80	
201	PC	FP	2,5 m	624018**	80	
202	PC	FP	2,5 m	624025	80	
Z 10	203	PC	FP	2,5 m	624032	80
	205	PC	FP	2,5 m	624056**	80
	211	PC	FP	2,5 m	624117**	80
	213	PC	FP	2,5 m	624131	80
	226	PC	FP	2,5 m	624261**	80
	228	PC	FP	2,5 m	624285**	80
	7037	PC	BM	2,5 m	623066	80
	8019	PC	BM	2,5 m	623172	80
	8024	PC	BM	2,5 m	623103**	80
	8028	PC	BM	2,5 m	623141	80
	9003	PC	BM	2,5 m	623011	80
	9005	PC	BM	2,5 m	623134	80
	1001	PC	BM	2,5 m	660924	100
	1011	PC	BM	2,5 m	661228**	100
	1015	PC	BM	2,5 m	660917	100
	105	PC	BM	2,5 m	660948	100
	107	PC	BM	2,5 m	660962	100
	119	PC	BM	2,5 m	661082	100
	125	PC	BM	2,5 m	661143**	100
	201	PC	FP	2,5 m	661310**	100
7037	PC	BM	2,5 m	660955	100	
8019	PC	BM	2,5 m	661068	100	
8024	PC	BM	2,5 m	660993**	100	
8028	PC	BM	2,5 m	661037**	100	
9003	PC	BM	2,5 m	660900	100	
9005	PC	BM	2,5 m	661020	100	
Z 12	201	PC	FP	2,5 m	661310**	100
	7037	PC	BM	2,5 m	660955	100
	8019	PC	BM	2,5 m	661068	100
	8024	PC	BM	2,5 m	660993**	100
	8028	PC	BM	2,5 m	661037**	100
	9003	PC	BM	2,5 m	660900	100
	9005	PC	BM	2,5 m	661020	100

** Na zamówienie/ Available on request/ Auf Anfrage verfügbar *** Outlet



Profile krawędziowe/ Edge profiles/ Kantenprofile

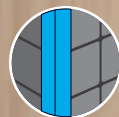

ZZ 8 PVC

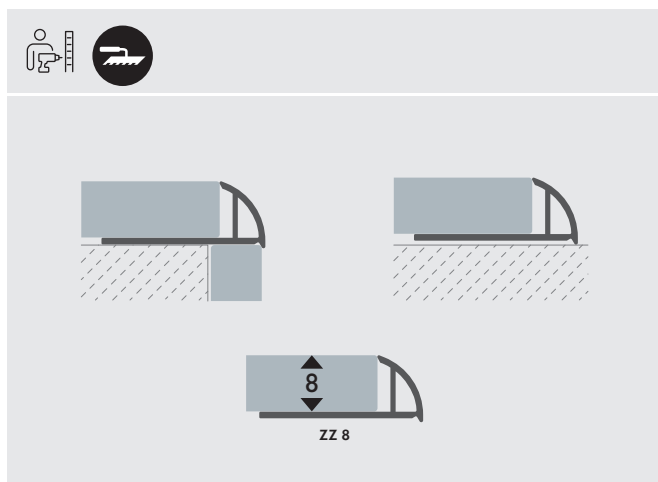

ZZ 8



Code	Material	Finish	Length	Product Code	Width
9003	PC	BM	2,5 m	829956	80
102	PC	BM	2,5 m	829963	80
103	PC	BM	2,5 m	829970	80
105	PC	BM	2,5 m	829987	80
114	PC	BM	2,5 m	829994	80
119	PC	BM	2,5 m	830006	80
133	PC	BM	2,5 m	830013	80
138	PC	BM	2,5 m	830020	80
142	PC	BM	2,5 m	830037	80

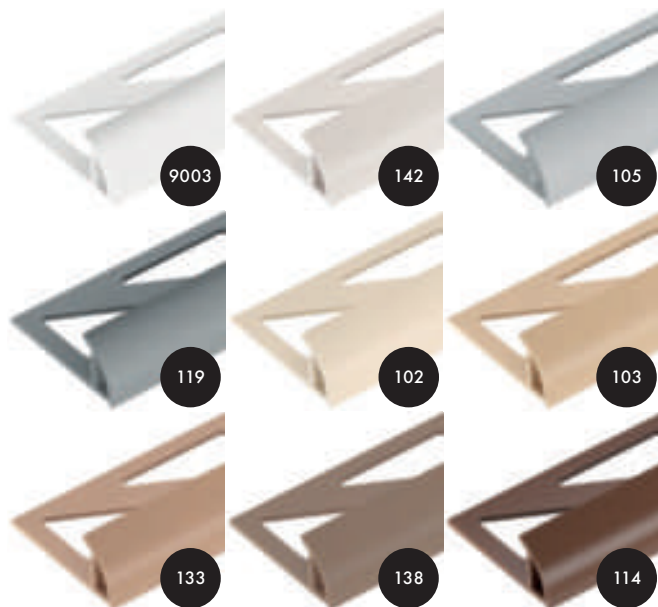

(BM) Produkt barwiony w masie - matowy / Full body coloured product - matt / Einfarbiges Produkt - matt, (FP) Folia polysk / Gloss foil / Folie glänzend



PROFIL WEWNĘTRZNY WĄSKI NARROW INNER TRIM SCHMALE INNENLEISTE

PVC

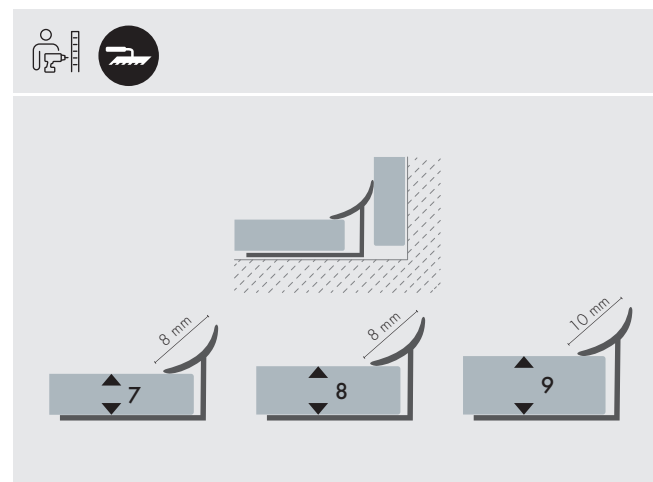

Code	Material	Finish	Length	Product Code	Width
9003	PC	BM	2,5 m	607516	60
105	PC	BM	2,5 m	607554**	60
107	PC	BM	2,5 m	607578**	60
119	PC	BM	2,5 m	607691**	60
125	PC	BM	2,5 m	607752**	60
1001	PC	BM	2,5 m	607530**	60
1015	PC	BM	2,5 m	607523**	60
7037	PC	BM	2,5 m	607561**	60
8024	PC	BM	2,5 m	607608**	60
9003	PC	BM	2,5 m	611513	60
105	PC	BM	2,5 m	611551	60
119	PC	BM	2,5 m	611698	60
122	PC	BM	2,5 m	611728**	60
125	PC	BM	2,5 m	611759**	60
138	PC	BM	2,5 m	611889**	60
203	PC	FP	2,5 m	612534**	60

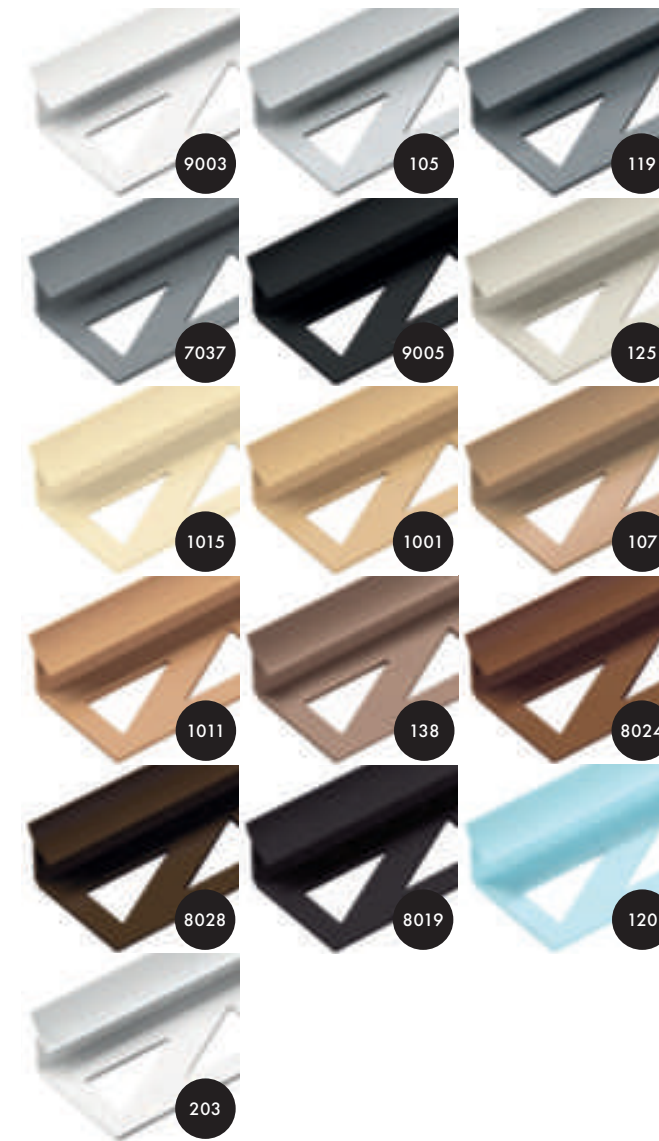

Code	Material	Finish	Length	Product Code	Width
1001	PC	BM	2,5 m	611537	60
1011	PC	BM	2,5 m	611834**	60
1015	PC	BM	2,5 m	611520**	60
7037	PC	BM	2,5 m	611568**	60
8019	PC	BM	2,5 m	611674**	60
8028	PC	BM	2,5 m	611643**	60
9003	PC	BM	2,5 m	615511	80
105	PC	BM	2,5 m	615559	80
107	PC	BM	2,5 m	615573**	80
119	PC	BM	2,5 m	615696**	80
120	PC	BM	2,5 m	615702**	80
125	PC	BM	2,5 m	615757**	80
138	PC	BM	2,5 m	615887**	80
1001	PC	BM	2,5 m	615535	80
1011	PC	BM	2,5 m	615832**	80
1015	PC	BM	2,5 m	615528	80
7037	PC	BM	2,5 m	615566	80
8019	PC	BM	2,5 m	615672**	80
8024	PC	BM	2,5 m	615603**	80
8028	PC	BM	2,5 m	615641**	80
9005	PC	BM	2,5 m	615634**	80

** Na zamówienie / Available on request / Auf Anfrage verfügbar *** Outlet



PROFIL WĘWĘTRZNY SZEROKI
WIDE INNER TRIM
BREITE INNENLEISTE

PVC

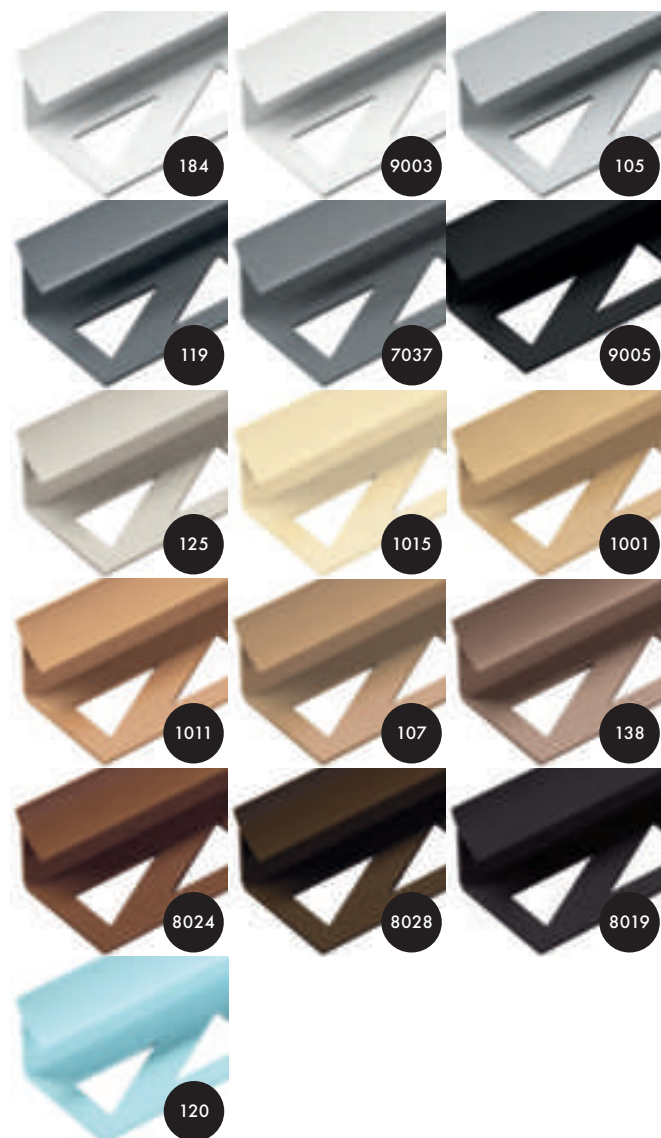
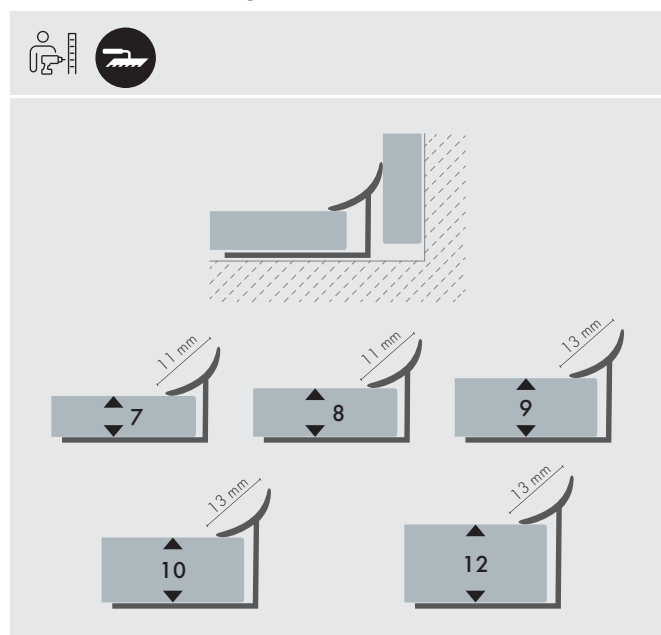

	9003	PC	BM	2,5 m	640902	60
	105	PC	BM	2,5 m	640940	60
	107	PC	BM	2,5 m	640964**	60
	125	PC	BM	2,5 m	641145**	60
	202	PC	FP	2,5 m	641329**	60
	213	PC	FP	2,5 m	641435**	60
WS 07	1001	PC	BM	2,5 m	640926	60
	1011	PC	BM	2,5 m	641220**	60
	1015	PC	BM	2,5 m	640919	60
	7037	PC	BM	2,5 m	640957**	60
	8019	PC	BM	2,5 m	641060**	60
	8024	PC	BM	2,5 m	640995**	60
	8028	PC	BM	2,5 m	641039**	60
	9005	PC	BM	2,5 m	641022**	60
	9003	PC	BM	2,5 m	641626	80
	105	PC	BM	2,5 m	641664	80
	107	PC	BM	2,5 m	641688**	80
	125	PC	BM	2,5 m	641862**	80
WS 08	1001	PC	BM	2,5 m	641640	80
	1011	PC	BM	2,5 m	641947**	80
	1015	PC	BM	2,5 m	641633	80
	7037	PC	BM	2,5 m	641671**	80
	8019	PC	BM	2,5 m	641787**	80
	8024	PC	BM	2,5 m	641718**	80
	9005	PC	BM	2,5 m	641749	80
	9003	PC	BM	2,5 m	642340	60
	105	PC	BM	2,5 m	642388	60
	107	PC	BM	2,5 m	642401	60
	119	PC	BM	2,5 m	642524	60
	120	PC	BM	2,5 m	642531**	60
	125	PC	BM	2,5 m	642586	60
	138	PC	BM	2,5 m	642715**	60
WS 09	213	PC	FP	2,5 m	642876	60
	1001	PC	BM	2,5 m	642364	60
	1011	PC	BM	2,5 m	642661	60
	1015	PC	BM	2,5 m	642357	60
	7037	PC	BM	2,5 m	642395	60
	8019	PC	BM	2,5 m	642500	60
	8024	PC	BM	2,5 m	642432	60
	8028	PC	BM	2,5 m	642470	60
	9005	PC	BM	2,5 m	642463	60

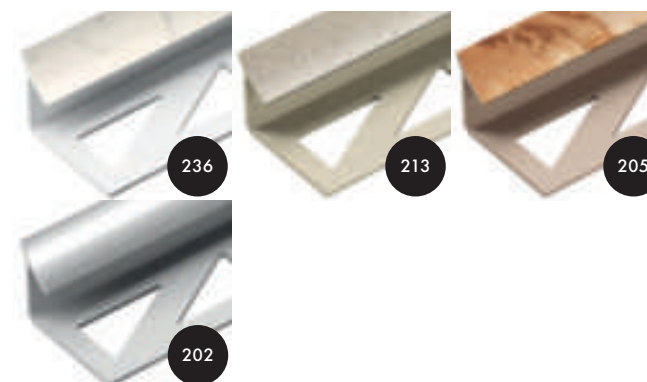

	9003	PC	BM	2,5 m	623516	60
	105	PC	BM	2,5 m	623554	60
	107	PC	BM	2,5 m	623578**	60
	119	PC	BM	2,5 m	623691**	60
	125	PC	BM	2,5 m	623752	60
	138	PC	BM	2,5 m	623882**	60
	184	PC	BM	2,5 m	678646**	60
	202	PC	FP	2,5 m	624520	60
WS 10	205	PC	FP	2,5 m	624551**	60
	1001	PC	BM	2,5 m	623530	60
	1011	PC	BM	2,5 m	623837**	60
	1015	PC	BM	2,5 m	623523	60
	7037	PC	BM	2,5 m	623561	60
	8019	PC	BM	2,5 m	623677**	60
	8024	PC	BM	2,5 m	623608**	60
	8028	PC	BM	2,5 m	623646	60
	9005	PC	BM	2,5 m	623639	60
	9003	PC	BM	2,5 m	661570	50
	105	PC	BM	2,5 m	661617	50
WS 12	236	PC	BM	2,5 m	846953	50
	1001	PC	BM	2,5 m	661594	50
	1015	PC	BM	2,5 m	661587	50
	9005	PC	BM	2,5 m	661693**	50

** Na zamówienie/ Available on request/ Auf Anfrage verfügbar *** Outlet



**PROFIL OZDOBNY
DECORATIVE TILE TRIM
DEKORATIVE LEISTE FÜR FLIESEN**

PVC

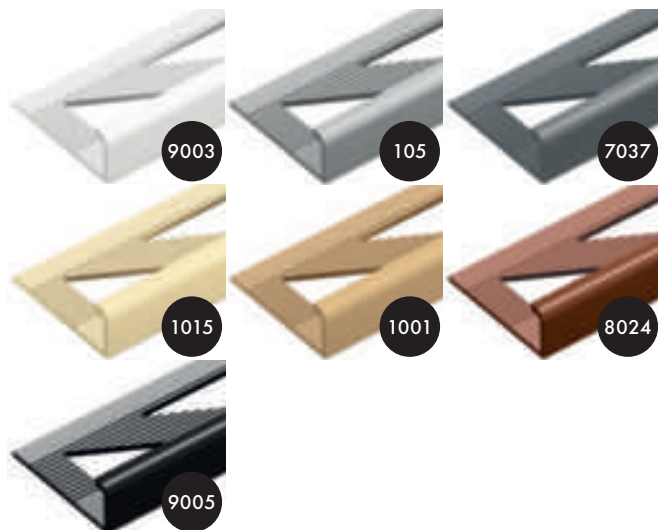
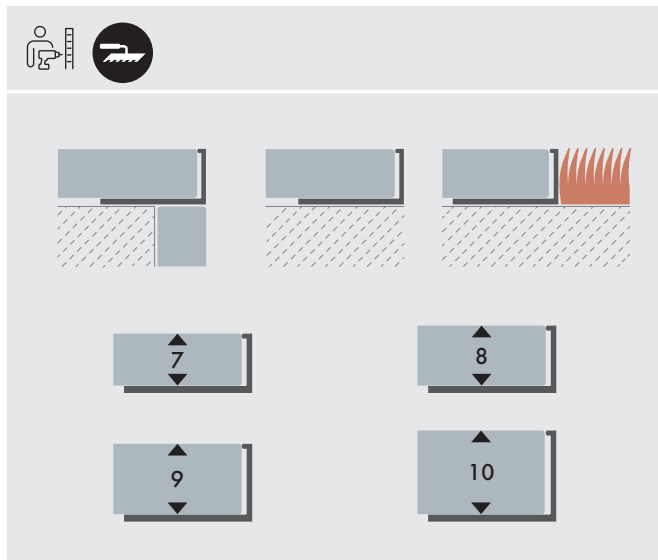

LO 07	9003	PC	BM	2,5 m	620515	100
	105	PC	BM	2,5 m	620553**	50
	1001	PC	BM	2,5 m	620539**	100
	1015	PC	BM	2,5 m	620522**	100
LO 08	9005	PC	BM	2,5 m	620638**	100
	9003	PC	BM	2,5 m	622519	100
	1001	PC	BM	2,5 m	622533	100
	7037	PC	BM	2,5 m	622564	100
LO 09	8024	PC	BM	2,5 m	622601**	100
	9005	PC	BM	2,5 m	622632**	100
	9003	PC	BM	2,5 m	624322	90
	105	PC	BM	2,5 m	624360**	90
LO 10	1001	PC	BM	2,5 m	624346**	90
	1015	PC	BM	2,5 m	624339**	90
	7037	PC	BM	2,5 m	624377**	90
	9005	PC	BM	2,5 m	624445**	90
LO 10	9003	PC	BM	2,5 m	625015	90
	105	PC	BM	2,5 m	625053	90
	1001	PC	BM	2,5 m	625039	90
	1015	PC	BM	2,5 m	625022	90
LO 10	7037	PC	BM	2,5 m	625060	90
	8024	PC	BM	2,5 m	625107**	90
	9005	PC	BM	2,5 m	625138	90
	LO12	9003	PC	BM	2,5 m	653476**

** Na zamówienie/ Available on request/ Auf Anfrage verfügbar *** Outlet

(BM) Produkt barwiony w masie - matowy/ Full body coloured product - matt/ Einfarbiges Produkt - matt, (AM) Produkt anodowany - matowy/ Anodised product - matt/ Eloxiertes Produkt - matt, (S) Wykończenie surowe/ Raw finish/ Rohe Oberfläche, (SP) Polerowane aluminium lub mosiądz/ Polished aluminium or brass/ Poliertes Aluminium oder Messing, (PB) Stal nierdzewna naturalna/ Natural stainless steel/ Edelstahl natürlich



W

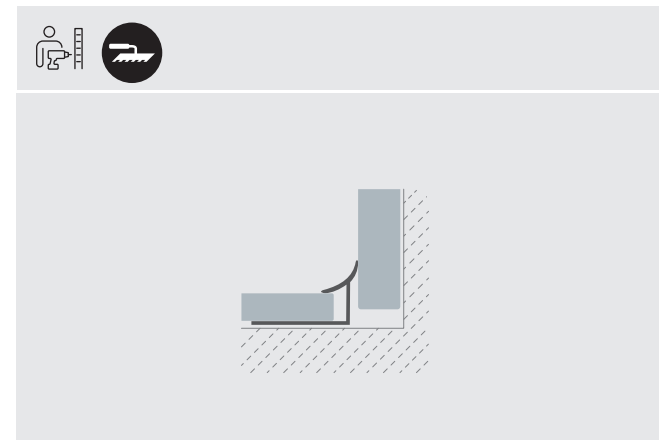

ALUMINIUM I MOSIADZ/ALUMINIUM AND BRASS/ ALUMINIUM UND MESSING

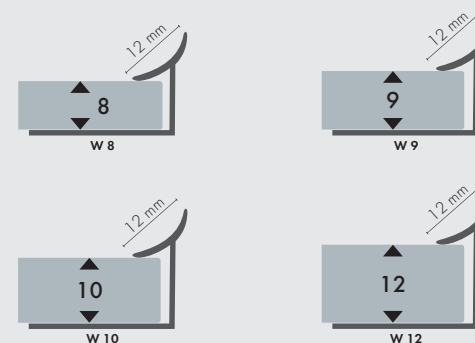

STAL NIERDZEWNA/ STAINLESS STEEL/ EDELSTAHL

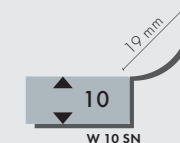

W 08	C0	AL	AM	2,5 m	819162**	10
	C23	AL	AM	2,5 m	819179**	10
W 09	N	AL	S	1 m	803802**	10
	N	AL	S	2 m	803826**	10
W 09	N	AL	S	2,5 m	803833	10
	C0	AL	AM	2,5 m	803864	10
	C23	AL	AM	2,5 m	803871**	10
W 10	N	MS	S	1 m	813801***	10
	N	SN	PB	2,5 m	820786**	10
W 10	C0	AL	AM	2,5 m	819124**	10
	C23	AL	AM	2,5 m	819131**	10
W 12	C0	AL	AM	2,5 m	819148**	10
	C23	AL	AM	2,5 m	819155**	10

** Na zamówienie/ Available on request/ Auf Anfrage verfügbar *** Outlet

AL ALUMINIUM ANODOWANE
ANODIZED ALUMINIUM
ELOXIERTES ALUMINIUM



MS MOSIADZ
BRASS
MESSING



SN STAL NIERDZEWNA
STAINLESS STEEL
EDELSTAHL

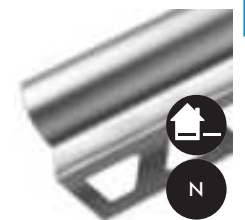



WT

K 2525

PROFIL OZDOBNY DOW DECORATIVE DOW TILE TRIM DEKORATIVE DOW-PROFIL

PROFIL OZDOBNY DO 25 DECORATIVE DO 25 TILE TRIM DEKORATIVE DO 25-PROFIL

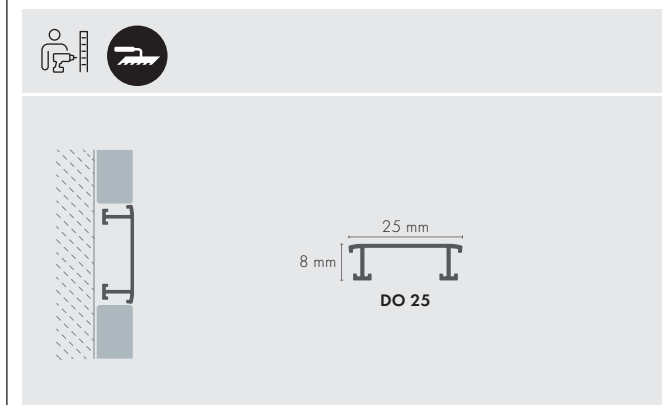
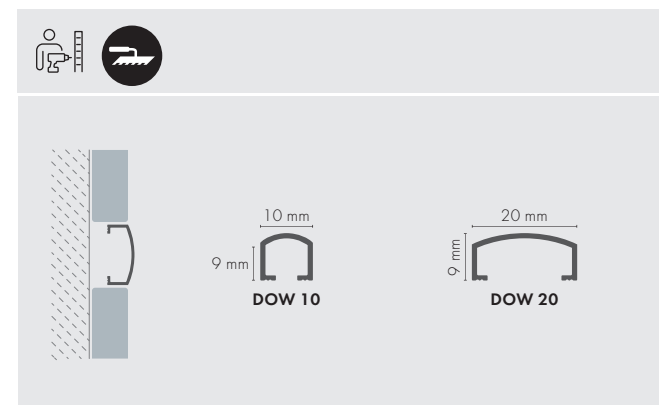
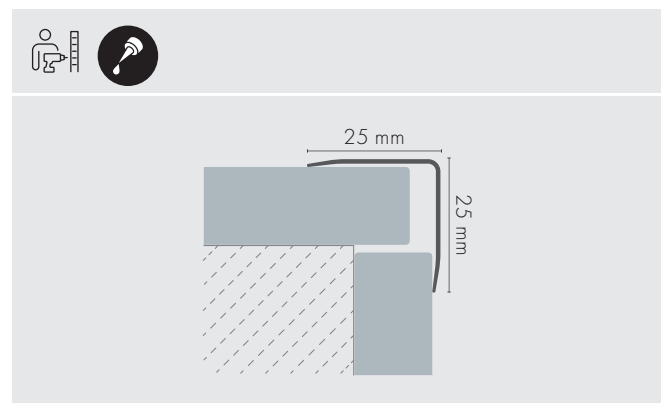
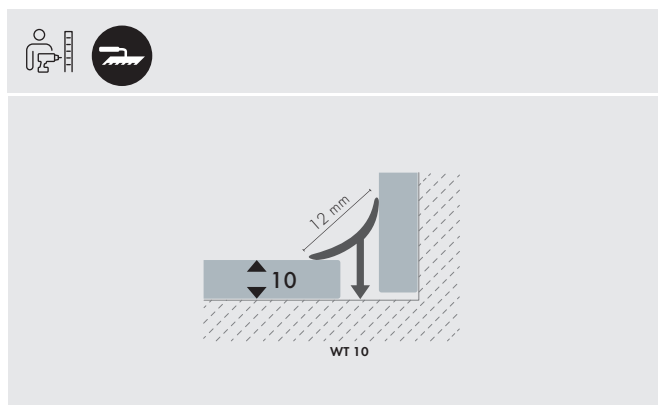

WT 10	CO	AL	AM	2,5 m	863165	10
-------	----	----	----	-------	--------	----

N	SN	PB	2,5 m	892233	10
---	----	----	-------	--------	----

DOW 10	CO	AL	AM	2,5 m	825293	10
DOW 20	CO	AL	AM	2,5 m	825316	10

DO 25	C1	AL	AM	2,5 m	893117	10
-------	----	----	----	-------	--------	----

AL ALUMINIUM ANODOWANE
ANODIZED ALUMINIUM
ELOXIERTES ALUMINIUM



SN STAL NIERDZEWNA
STAINLESS STEEL
EDELSTAHL



AL ALUMINIUM ANODOWANE
ANODIZED ALUMINIUM
ELOXIERTES ALUMINIUM



AL ALUMINIUM ANODOWANE
ANODIZED ALUMINIUM
ELOXIERTES ALUMINIUM



(AM) Produkt anodowany - matowy / Anodised product - matt / Eloxiertes Produkt - matt, (PB) Stal nierdzewna naturalna / Natural stainless steel / Edelstahl natürlich,



U 20



U 10



**PROFIL OZDOBNY U
DECORATIVE U TILE TRIM
DEKORATIVE U-PROFIL**

SN

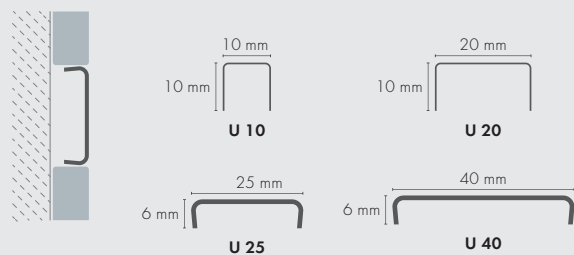

U 40

U 10	ZL	SN	VP	2,5 m	832895	10
U 10	SR	SN	VP	2,5 m	832888	10
U 20	ZL	SN	VP	2,5 m	832949	10
U 20	SR	SN	VP	2,5 m	832901	10
U25	SZ	SN	SZ	2,5 m	891519	10
U 40	SZ	SN	SZ	2,5 m	891526	10

SN STAL NIERDZEWNA
STAINLESS STEEL
EDELSTAHL

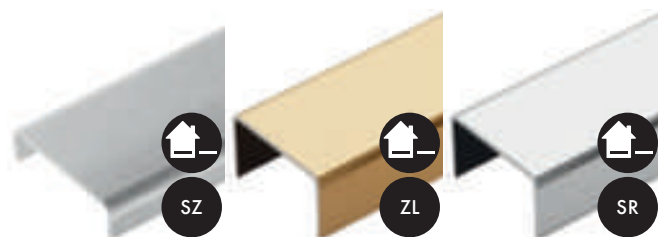

(VP) Wysoki połysk - stal nierdzewna/ Stainless steel - high gloss/ Hochglanz - Edelstahl, (SZ) Stal nierdzewna szczotkowana/ Brushed stainless steel/ Edelstahl gebürstet, (CP) Chrom połysk/ Chrome gloss/ Chrom glänzend, (SP) Polerowane aluminium lub mosiądz/ Polished aluminium or brass/ Poliertes Aluminium oder Messing



**PROFIL OZDOBNY DU
DECORATIVE DU TILE TRIM
DEKORATIVE DU-PROFIL**

MS

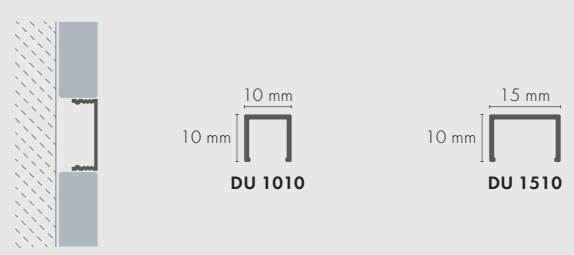

DU 101012	CH	MS	CP	2,7 m	828119	10
DU 101012	P	MS	SP	2,7 m	825613	10
DU 151012	CH	MS	CP	2,7 m	828126	10
DU 151012	P	MS	SP	2,7 m	825620	10

MS MOSIĄDZ
BRASS
MESSING

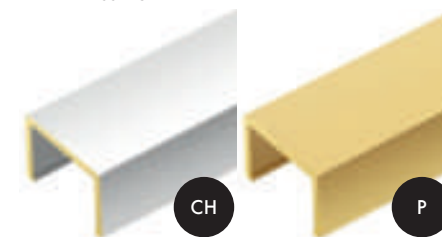



DYS 85 PVC

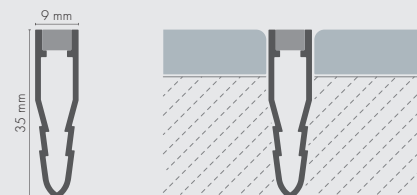

DYS 85	7046	PC	BM	2,5 m	829109	20
--------	------	----	----	-------	--------	----



DY10G/ DY12G

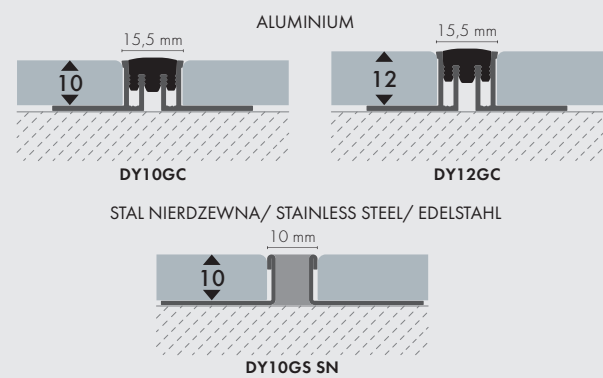

DY10G	N	AL	S	2,5 m	826788**	10
DY10GS	N	SN	PB	2,5 m	824012***	10
DY12G	N	AL	S	2,5 m	826795**	10

** Na zamówienie/ Available on request/ Auf Anfrage verfügbar *** Outlet

AL ALUMINIUM ANODOWANE
ANODIZED ALUMINIUM
ELOXIERTES ALUMINIUM

SN STAL NIERDZEWNA
STAINLESS STEEL
EDELSTAHL



DYW 10 PVC

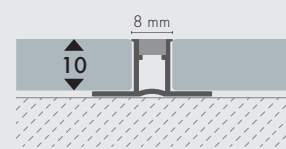

DYW 10	7046	PC	BM	2,5 m	829116**	40
--------	------	----	----	-------	----------	----

** Na zamówienie/ Available on request/ Auf Anfrage verfügbar



DY 10/ DY 20 PVC

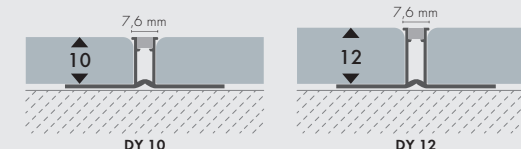

DY 10	105	PC	BM	2,5 m	678035	10
	107	PC	BM	2,5 m	678042**	10
	1001	PC	BM	2,5 m	678028	10
	7037	PC	BM	2,5 m	678011	10
DY 12	8028	PC	BM	2,5 m	678059	10
	105	PC	BM	2,5 m	678073	10
	107	PC	BM	2,5 m	678509**	10
	1001	PC	BM	2,5 m	678066**	10
	7037	PC	BM	2,5 m	678080	10

** Na zamówienie/ Available on request/ Auf Anfrage verfügbar



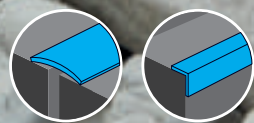
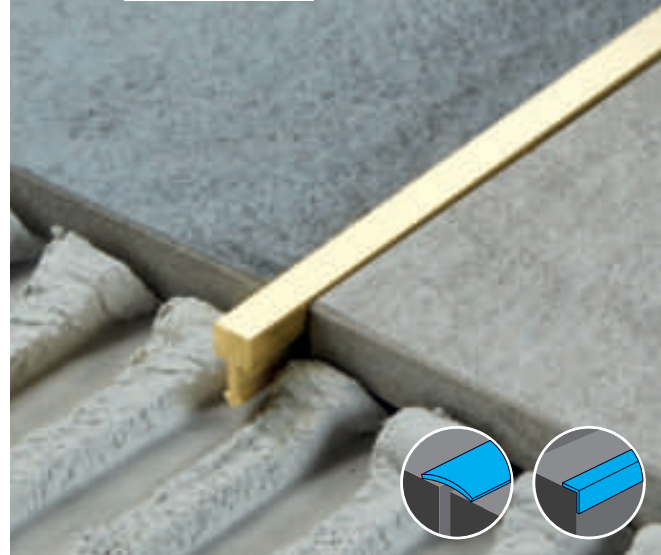

FUGA 5

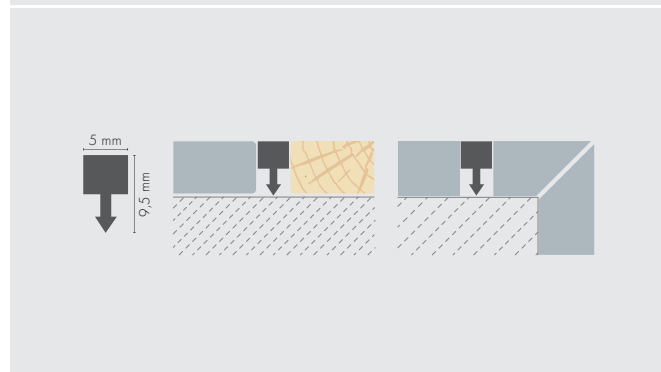

N	MS	S	2 m	812927	10
N	MS	S	2,5 m	812934	10
P	MS	SP	2,5 m	823961**	10

** Na zamówienie/ On request/ Auf Anfrage *** Outlet

MS MOSIADZ BRASS MESSING

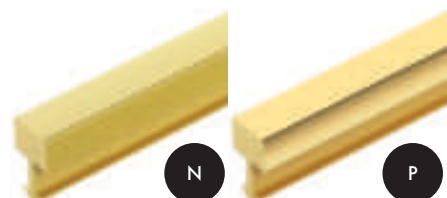

(CP) Chrom polnyk/ Chrome gloss/ Chrom glänzend, (S) Wykończenie surowe/ Raw finish/ Rohe Oberfläche, (SP) Polerowane aluminium lub mosiądz/ Polished aluminium or brass/ Poliertes Aluminium oder Messing (AM) Produkt anodowany - matowy/ Anodised product - matt/ Eloxiertes Produkt - matt, (AP) Produkt anodowany - polnyk/ Anodised product - gloss/ Eloxiertes Produkt - glänzend, (OM) Okleina mat/ Foil with wood finishes/ Folie mit Holzoptik

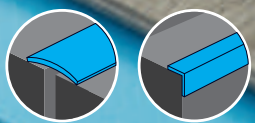

FG 14/ 20

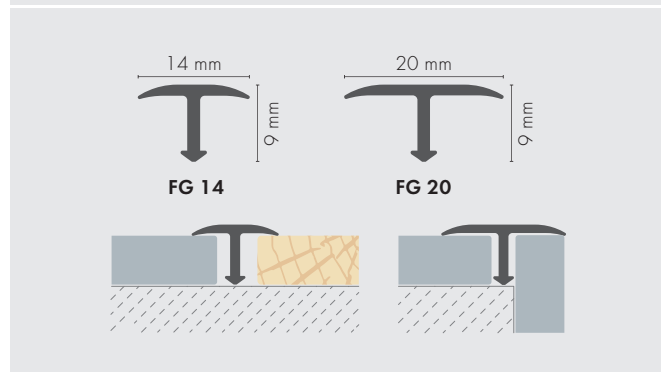

AL ALUMINIUM ANODOWANE ANODIZED ALUMINIUM ELOXIERTES ALUMINIUM

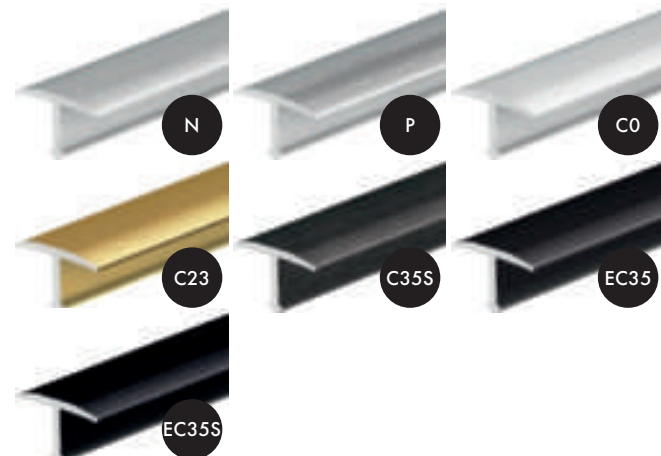

N	AL	S	2,5 m	846137	10
P	AL	SP	2,5 m	846038**	10
CO	AL	AM	2,5 m	846830	10
C23	AL	AM	2,5 m	846939	10
C35S	AL	AM	1 m	826542	10
EC35	AL	AP	1 m	826528**	10
EC35	AL	AP	2,5 m	826511	10
C35S	AL	AM	2,5 m	826535	10
EC35S	AL	AP	1 m	826504**	10
EC35S	AL	AP	2,5 m	826498	10
DB	AL	OM	2,5 m	892134**	10
DW	AL	OM	2,5 m	893407	10
SR	AL	OM	2,5 m	801877**	10
DO	AL	OM	2,5 m	801815**	10
DJ	AL	OM	2,5 m	861284	10
DG	AL	OM	2,5 m	893391	10
DN	AL	OM	2,5 m	861291	10
DH	AL	OM	2,5 m	801730	10
DC	AL	OM	2,5 m	801723	10
DS	AL	OM	2,5 m	892141	10
DZ	AL	OM	2,5 m	861314**	10
D	AL	OM	2,5 m	875410	10
B	AL	OM	2,5 m	875427**	10
DP	AL	OM	2,5 m	861307**	10
RZ	AL	OM	2,5 m	875519**	10
R	AL	OM	2,5 m	875496**	10
T	AL	OM	2,5 m	875526**	10
V	AL	OM	2,5 m	875533**	10
RC	AL	OM	2,5 m	875502***	10
P	MS	SP	2,5 m	856037	10
P	MS	SP	2,70	810121	10
N	AL	S	2,5 m	846434	10
P	AL	SP	2,5 m	846335**	10
CO	AL	AM	2,5 m	847431	10
C23	AL	AM	2,5 m	847530	10
EC35	AL	AP	1 m	826467**	10
EC35	AL	AP	2,5 m	826450	10
C35S	AL	AM	1 m	826481	10
C35S	AL	AM	2,5 m	826474	10
EC35S	AL	AP	1 m	826443**	10
EC35S	AL	AP	2,5 m	826436	10
DB	AL	OM	2,5 m	892806	10
DW	AL	OM	2,5 m	893414	10
SR	AL	OM	2,5 m	801969	10
DO	AL	OM	2,5 m	801914	10
DJ	AL	OM	2,5 m	860034	10
DG	AL	OM	2,5 m	893421	10
DN	AL	OM	2,5 m	860027	10
DH	AL	OM	2,5 m	801907	10
DC	AL	OM	2,5 m	801891	10
DS	AL	OM	2,5 m	892905	10
DZ	AL	OM	2,5 m	860010	10
D	AL	OM	2,5 m	875618	10
B	AL	OM	2,5 m	875625**	10

FG14

FG20



DP	AL	OM	2,5 m	860041	10
RZ	AL	OM	2,5 m	875717	10
R	AL	OM	2,5 m	875694**	10
T	AL	OM	2,5 m	875724	10
V	AL	OM	2,5 m	875731	10
CH	MS	CP	2,7 m	825590**	10
P	MS	SP	2,5 m	856334**	10
P	MS	SP	2,7 m	819605	10

** Na zamówienie/ On request/ Auf Anfrage *** Outlet

MS MOSIADZ BRASS MESSING



AL AC4 ALUMINIUM LAMINOWANE LAMINATED ALUMINIUM LAMINIERTES ALUMINIUM

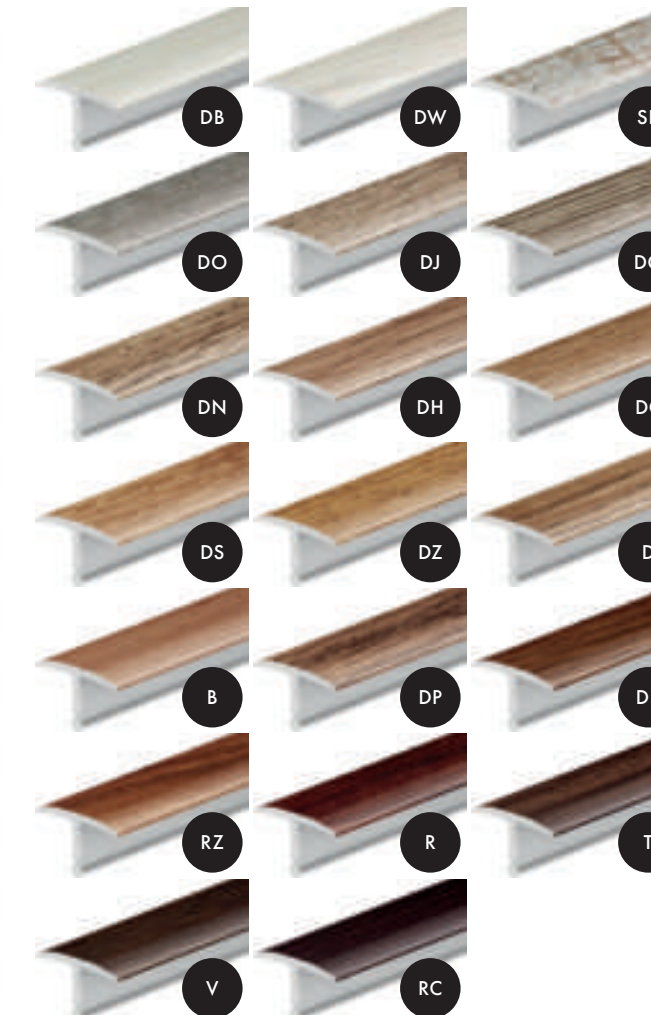

Profile dylatacyjne/ Expansion joint profiles/ Dehnungsfugenprofile

37

Profile dylatacyjne/ Expansion joint profiles/ Dehnungsfugenprofile

36



T 13/ 14/ 18/ 25/ 26

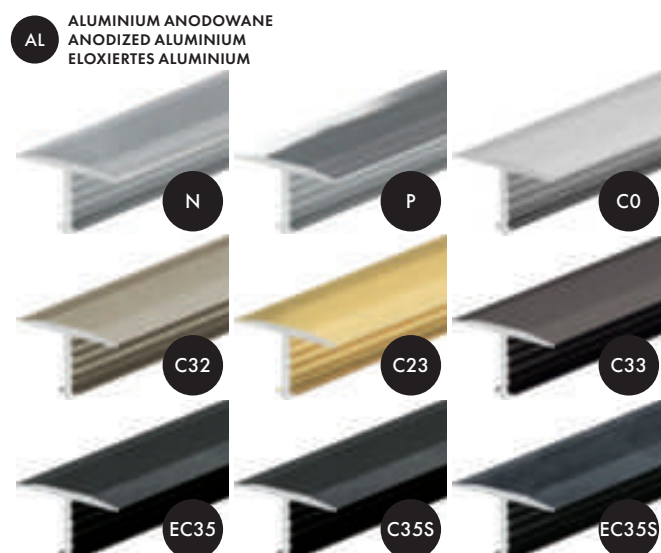
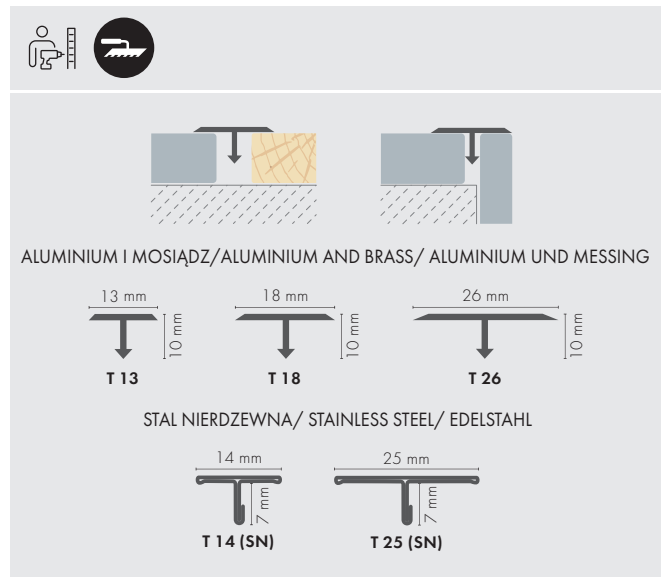

N	AL	S	1 m	805400	10	
N	AL	S	2 m	805424	10	
N	AL	S	2,5 m	805431	10	
P	AL	SP	1 m	802409	10	
P	AL	SP	2 m	802423	10	
P	AL	SP	2,5 m	802430	10	
C0	AL	AM	1 m	802454	10	
C0	AL	AM	2,5 m	802461	10	
C32	AL	AM	1 m	860836	10	
C32	AL	AM	2,5 m	802492	10	
C23	AL	AM	1 m	802485	10	
C23	AL	AM	2,5 m	802478	10	
C33	AL	AM	2,5 m	808784**	10	
EC35	AL	AP	1 m	826276	10	
EC35	AL	AP	2,5 m	826283	10	
C35S	AL	AM	1 m	826252	10	
C35S	AL	AM	2,5 m	826269	10	
EC35S	AL	AP	1 m	826290	10	
EC35S	AL	AP	2,5 m	826306	10	
CH	MS	CP	1 m	812453	10	
CH	MS	CP	2,5 m	860812	10	
CH	MS	CP	2,7 m	810190	10	
N	MS	S	1 m	815409	10	
N	MS	S	2 m	815423**	10	
N	MS	S	2,5 m	815430	10	
N	MS	S	3 m	815447**	10	
P	MS	SP	1 m	812408	10	
P	MS	SP	2 m	812422**	10	
P	MS	SP	2,5 m	812439	10	
P	MS	SP	2,7 m	824128**	10	
P	MS	SP	3 m	812446**	10	
T 14	N	SN	PB	2,5 m	891571	10
N	AL	S	1 m	805509	10	
N	AL	S	2 m	805523	10	
N	AL	S	2,5 m	805530	10	
N	AL	S	3 m	805547	10	
P	AL	SP	1 m	802607	10	
P	AL	SP	2 m	802621**	10	
P	AL	SP	2,5 m	802638	10	
P	AL	SP	3 m	802645**	10	
C0	AL	AM	1 m	802683	10	
C0	AL	AM	2,5 m	802652	10	
T 18	C0	AL	AM	3 m	808944**	10
C32	AL	AM	1 m	860850	10	
C32	AL	AM	2,5 m	809033	10	
C23	AL	AM	1 m	860843	10	
C23	AL	AM	2,5 m	802669	10	
C23	AL	AM	3 m	802676**	10	
C33	AL	AM	2,5 m	809088**	10	
EC35	AL	AP	1 m	826337	10	
EC35	AL	AP	2,5 m	826344	10	
C35S	AL	AM	1 m	826313	10	
C35S	AL	AM	2,5 m	826320	10	

C35S	AL	AM	1 m	826313	10	
C35S	AL	AM	2,5 m	826320	10	
EC35S	AL	AP	1 m	826351	10	
EC35S	AL	AP	2,5 m	826368	10	
CH	MS	CP	1 m	812651	10	
CH	MS	CP	2 m	812668**	10	
CH	MS	CP	2,5 m	860829	10	
CH	MS	CP	2,7 m	819643	10	
N	MS	S	1 m	815508**	10	
N	MS	S	2 m	815522**	10	
N	MS	S	2,5 m	815539	10	
P	MS	SP	1 m	812606**	10	
P	MS	SP	2 m	812620**	10	
P	MS	SP	2,5 m	812637	10	
P	MS	SP	2,7 m	819650	10	
P	MS	SP	3 m	812644**	10	
T 25	N	SN	PB	2,5 m	891588	10
N	AL	S	1 m	805608**	10	
N	AL	S	2 m	805622**	10	
N	AL	S	2,5 m	805639	10	
N	AL	S	3 m	805646**	10	
P	AL	SP	1 m	802805	10	
P	AL	SP	2 m	802829**	10	
P	AL	SP	2,5 m	802836	10	
C0	AL	AM	1 m	802850	10	
C0	AL	AM	2,5 m	802867	10	
C32	AL	AM	1 m	810015	10	
C32	AL	AM	2,5 m	802904	10	
C23	AL	AM	2,5 m	802874	10	
C33	AL	AM	2,5 m	802911**	10	
EC35	AL	AP	1 m	826399	10	
EC35	AL	AP	2,5 m	826405	10	
C35S	AL	AM	1 m	826375	10	
C35S	AL	AM	2,5 m	826382	10	
EC35S	AL	AP	1 m	826412	10	
EC35S	AL	AP	2,5 m	826429	10	
CH	MS	CP	2 m	812866**	10	
CH	MS	CP	2,5 m	826771	10	
CH	MS	CP	2,7 m	819667	10	
N	MS	S	2 m	815621**	10	
N	MS	S	2,5 m	815638	10	
P	MS	SP	1 m	812804**	10	
P	MS	SP	2 m	812828**	10	
P	MS	SP	2,5 m	812835	10	
P	MS	SP	2,7 m	821974**	10	

** Na zamówienie/ On request/ Auf Anfrage

(S) Wykończenie surowe/ Raw finish/ Rohe Oberfläche, (AM) Produkt anodowany - matowy/ Anodised product - matt/ Eloxiertes Produkt - matt, (AP) Produkt anodowany - polysk/ Anodised product - gloss/ Eloxiertes Produkt - glänzend, (SP) Polerowane aluminium lub mosiądz/ Polished aluminium or brass/ Poliertes Aluminium oder Messing, (CP) Chrom polysk/ Chrome gloss/ Chrom glänzend, (PB) Stal nierdzewna naturalna/ Natural stainless steel/ Edelstahl natürlich



D 14P/ D 15P/ D 17P

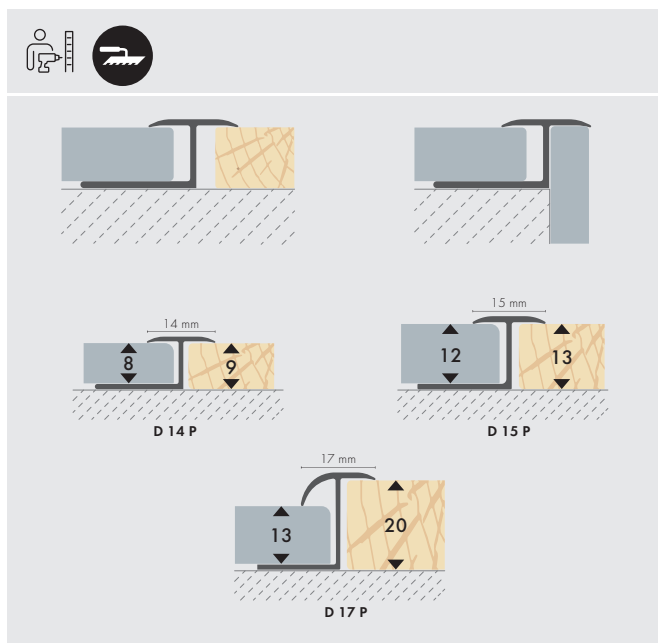

AL ALUMINIUM LAMINOWANE
LAMINATED ALUMINIUM
LAMINIERTES ALUMINIUM

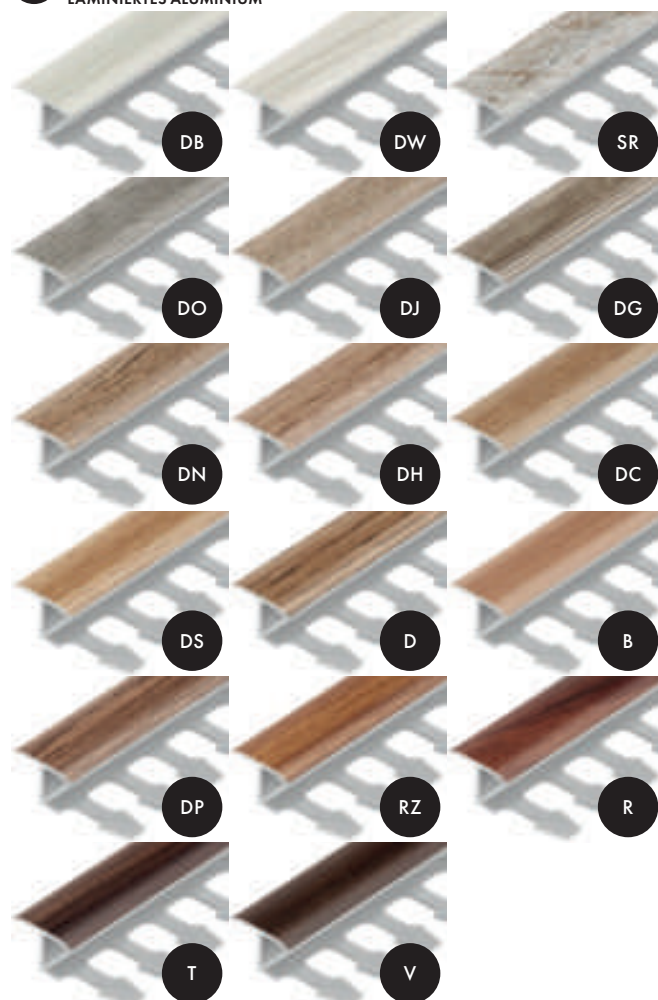

AL ALUMINIUM ANODOWANE
ANODIZED ALUMINIUM
ELOXIERTES ALUMINIUM

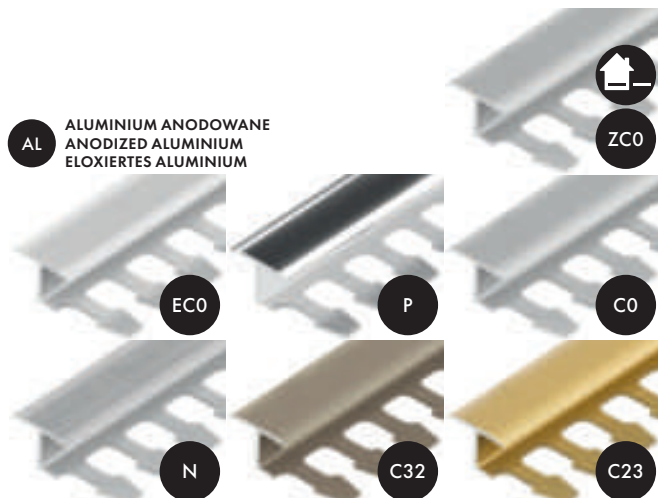

	Icon 1	Icon 2	Icon 3	Icon 4	Icon 5	Icon 6
D 14P	ECO	AL	AP	2,5 m	826740	10
	P	AL	SP	2,5 m	840982**	10
	N	AL	S	2,5 m	840937	10
	CO	AL	AM	2,5 m	841033	10
	ZCO	AL	AM	2,5 m	821837	10
	C32	AL	AM	2,5 m	841132	10
	C23	AL	AM	2,5 m	841088	10
	DB	AL	OM	2,5 m	892158**	10
	DW	AL	OM	2,5 m	893346**	10
	SR	AL	OM	2,5 m	804755**	10
	DO	AL	OM	2,5 m	804694**	10
	DJ	AL	OM	2,5 m	861208**	10
	DG	AL	OM	2,5 m	893339**	10
	DN	AL	OM	2,5 m	861215**	10
	DC	AL	OM	2,5 m	804670**	10
	DS	AL	OM	2,5 m	892165**	10
	D	AL	OM	2,5 m	841316**	10
	B	AL	OM	2,5 m	841323**	10
	DP	AL	OM	2,5 m	861222**	10
	RZ	AL	OM	2,5 m	800771**	10
R	AL	OM	2,5 m	841392**	10	
V	AL	OM	2,5 m	857027**	10	
D 15P	ECO	AL	AP	2,5 m	841002	10
	ECO	AL	AP	2,5 m	841019	10
	P	AL	SP	2,5 m	842115**	10
	N	AL	S	2,5 m	842108	10
	CO	AL	AM	2,5 m	842122	10
	C32	AL	AM	2,5 m	898402	10
	C23	AL	AM	2,5 m	842139	10
	DB	AL	OM	2,5 m	892783**	10
	DW	AL	OM	2,5 m	893360**	10
	SR	AL	OM	2,5 m	805301**	10
	DO	AL	OM	2,5 m	805288**	10
	DJ	AL	OM	2,5 m	861246**	10
D 17P	DG	AL	OM	2,5 m	893353**	10
	DN	AL	OM	2,5 m	861253**	10
	DH	AL	OM	2,5 m	805271**	10
	DC	AL	OM	2,5 m	805264**	10
	D	AL	OM	2,5 m	842214**	10
	DP	AL	OM	2,5 m	861260**	10
	RZ	AL	OM	2,5 m	842269**	10
	T	AL	OM	2,5 m	842283**	10
	V	AL	OM	2,5 m	842290**	10
	CO	AL	AM	2,5 m	841217**	10
	C23	AL	AM	2,5 m	841224**	10

** Na zamówienie/ Available on request/ Auf Anfrage verfügbar

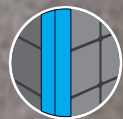

OKAP

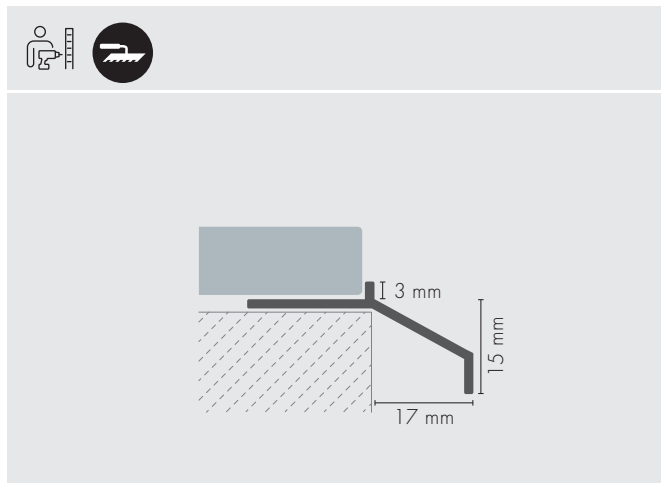

AL ALUMINIUM ANODOWANE
ANODIZED ALUMINIUM
ELOXIERTES ALUMINIUM



AL ALUMINIUM MALOWANE PROSZKOWO
POWDER-COATED ALUMINIUM
PULVERBESCHICHTETES ALUMINIUM

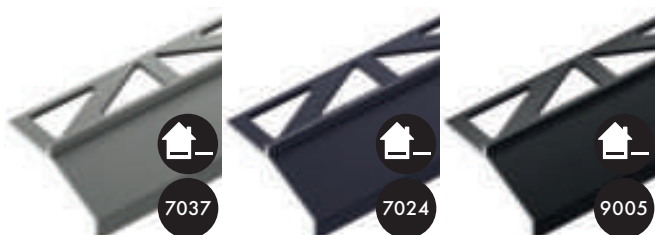

	Icon 1	Icon 2	Icon 3	Icon 4	Icon 5	Icon 6
N	AL	S	2 m	804021	10	
N	AL	S	2,5 m	804038	10	
N	AL	S	3 m	804045	10	
ZC0	AL	AM	2,5 m	829192	10	
ZC32	AL	AM	2,5 m	860959	10	
ZC23	AL	AM	2,5 m	804069**	10	
ZC33	AL	AM	2,5 m	898785	10	
ZC34	AL	AM	2,5 m	898792	10	
7024	AL	MP	2 m	820489	10	
7024	AL	MP	2,5 m	828034	10	
7037	AL	MP	2 m	805929**	10	
9005	AL	MM	2,5 m	830051	10	

** Na zamówienie/ Available on request/ Auf Anfrage verfügbar

(S) Wykończenie surowe/ Raw finish/ Rahe Oberfläche, (AM) Produkt anodowany - matowy/ Anodised product - matt/ Eloxiertes Produkt - matt, (MP) Malowanie proszkowe - połysk/ Powder coating - gloss/ Pulverbeschichtung - glänzend, (MM) Malowanie proszkowe - matowe/ Powder coating - matt/ Pulverbeschichtung - matt

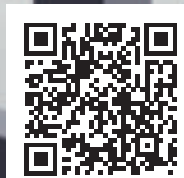

OKAP 100

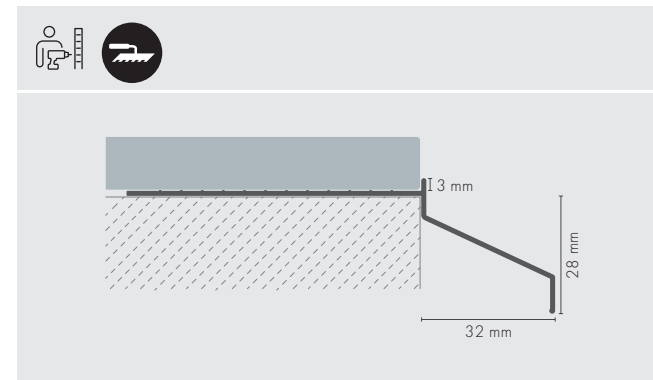

	Icon 1	Icon 2	Icon 3	Icon 4	Icon 5	Icon 6
OKAP100	7024	AL	MP	2 m	863028	5
	7037	AL	MP	2 m	863004	5
	8019	AL	MP	2 m	863011	5

AL ALUMINIUM MALOWANE PROSZKOWO
POWDER-COATED ALUMINIUM
PULVERBESCHICHTETES ALUMINIUM

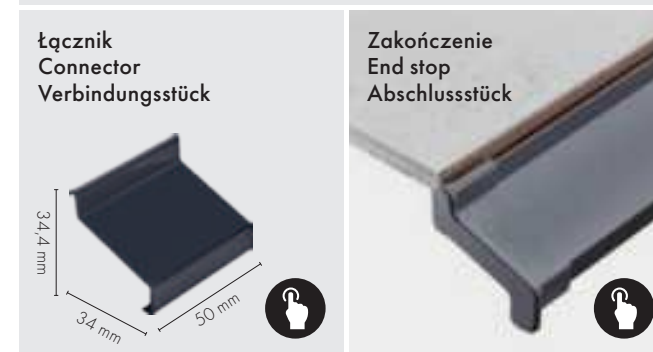
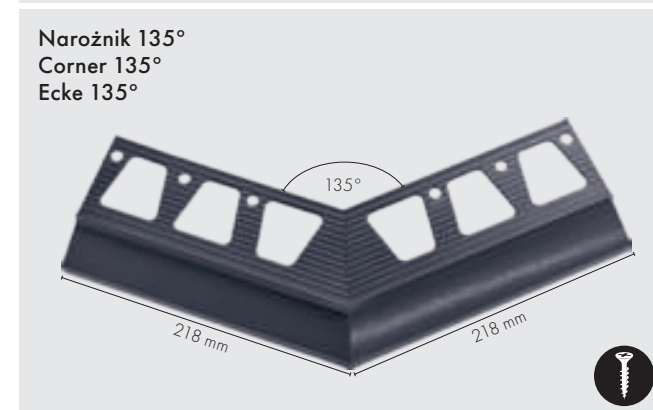
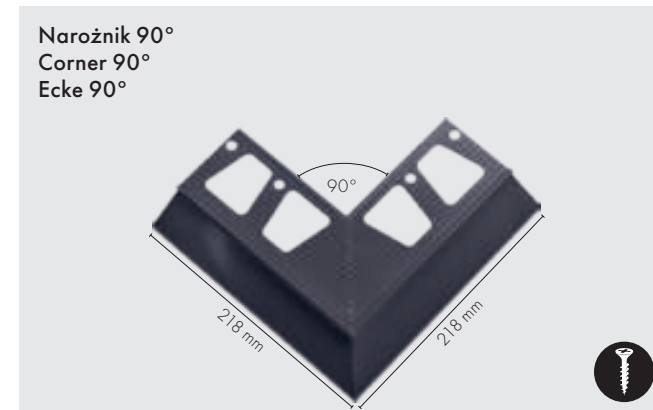
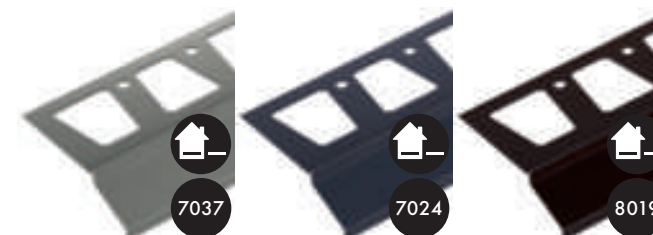

	Icon 1	Icon 2	Icon 3	Icon 4	Icon 5	Icon 6	
90°	x 1	x 2	7024	AL	MP	863103	22
			7037	AL	MP	863073	22
			8019	AL	MP	863097	22

	Icon 1	Icon 2	Icon 3	Icon 4	Icon 5	Icon 6	
135°	x 1	x 2	7024	AL	MP	810091	10
			7037	AL	MP	810060	10
			8019	AL	MP	810084	10

	Icon 1	Icon 2	Icon 3	Icon 4	Icon 5	Icon 6
	x 2	7024	AL	MP	863066	100
		7037	AL	MP	863042	100
		8019	AL	MP	863059	100



PROFIL WANNOWY PODPŁYTKOWY
UNDER-TILE BATHTUB PROFILE
UNTERFLIES-WANNENPROFIL

PVC

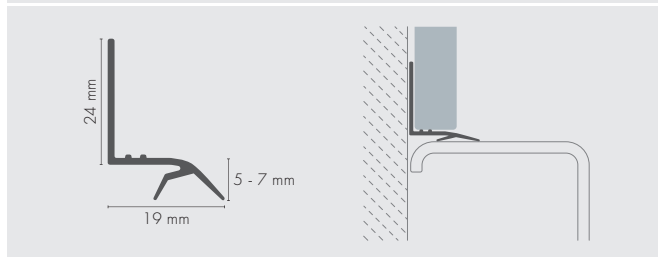

WNP	9003	PC	BM	1,83 m	609022	100
	9003	PC	BM	2,5 m	609039	100



9003

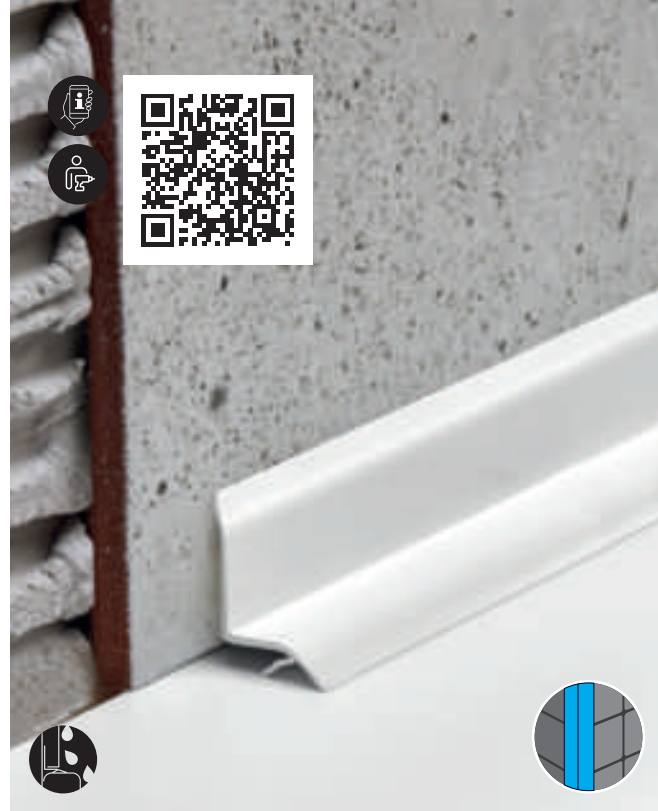

PROFIL WANNOWY SAMOPRZYLEPNY
SELF-ADHESIVE BATHTUB PROFILE
SELBSTKLEBENDES WANNENPROFIL

PVC

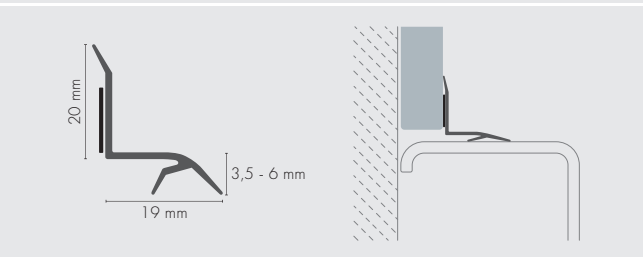

WNS	9003	PC	BM	1,83 m	626326	100
	9003 <td>PC <td>BM <td>2,5 m <td>670015 <td>100</td> </td></td></td></td>	PC <td>BM <td>2,5 m <td>670015 <td>100</td> </td></td></td>	BM <td>2,5 m <td>670015 <td>100</td> </td></td>	2,5 m <td>670015 <td>100</td> </td>	670015 <td>100</td>	100
	185 <td>PC <td>BM <td>2,5 m <td>699634 <td>60</td> </td></td></td></td>	PC <td>BM <td>2,5 m <td>699634 <td>60</td> </td></td></td>	BM <td>2,5 m <td>699634 <td>60</td> </td></td>	2,5 m <td>699634 <td>60</td> </td>	699634 <td>60</td>	60

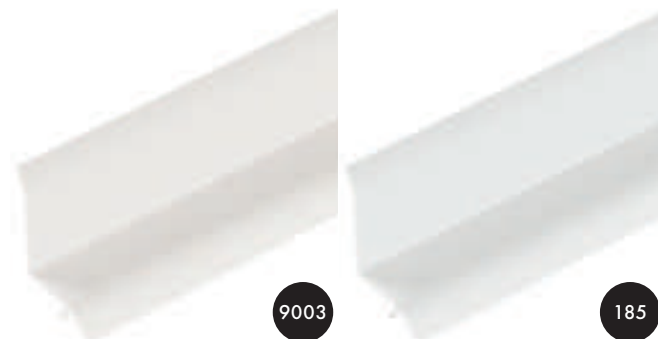

9003

185



UO 13

PVC

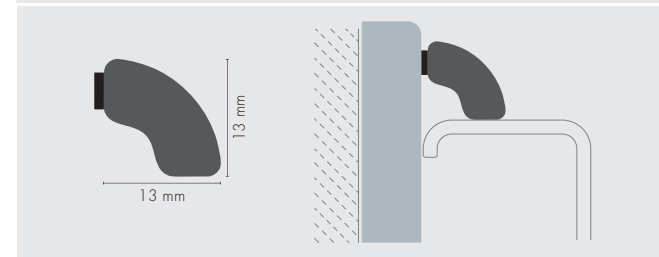

UO13	185	PC	BM	2,5 m	828720	80
------	-----	----	----	-------	--------	----



185



WNK

PVC

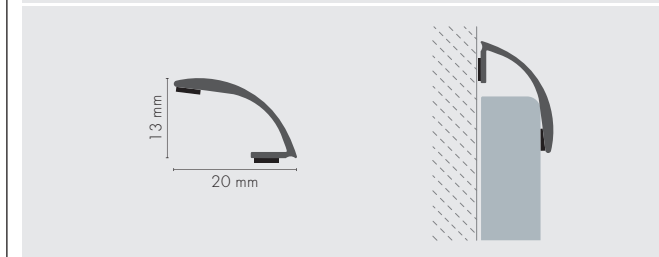

WNK	185	PC	BM	2,5 m	828737	90
-----	-----	----	----	-------	--------	----



185



ALU LED



Profil ALU LED nie jest sprzedawany razem z taśmą LED.
The ALU LED profile is not sold together with the LED strip.
Das ALU-LED-Profil wird nicht zusammen mit dem LED-Streifen verkauft.

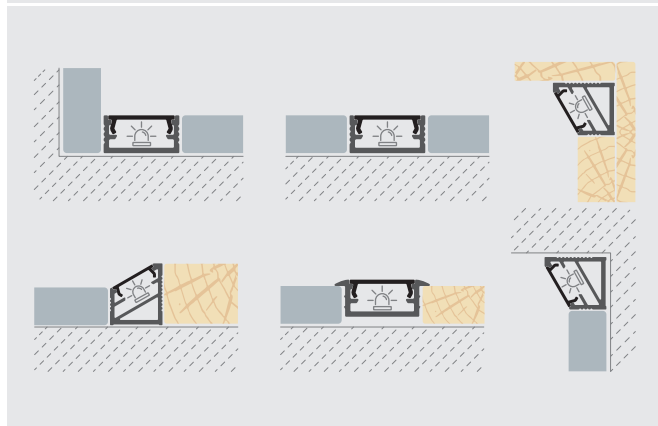

LEDOP	Profile	Material	Finish	Length	Part No.	Quantity
A	000	PC	BM	2 m	863561	10
B	001	PC	BM	2 m	863578	10
C	002	PC	BM	2 m	863592	10

LEDK3014	Profile	Material	Finish	Length	Part No.	Quantity
1	C0	AL	AM	2 m	863479	10
A	C0	AL	AM	1 m	863554	10
B	C0	AL	AM	1 m	863493	10
C	C0	AL	AM	1 m	863486	10
x2	ALSJ	PP	BM		611285	300

LED1412	Profile	Material	Finish	Length	Part No.	Quantity
2	C0	AL	AM	2 m	805783	10
A	C0	AL	AM	1 m	805806**	10
B	C0	AL	AM	1 m	805820**	10
C	C0	AL	AM	1 m	805813**	10

LED1407	Profile	Material	Finish	Length	Part No.	Quantity
3	C0	AL	AM	2 m	863431	10
A	C0	AL	AM	1 m	863448	10
B	C0	AL	AM	1 m	863455	10
C	C0	AL	AM	1 m	863462	10
x2	C0	AL	AM	1 m	863455	10

LEDL1407	Profile	Material	Finish	Length	Part No.	Quantity
4	C0	AL	AM	2 m	863509	10
A	C0	AL	AM	1 m	863516	10
B	C0	AL	AM	1 m	863547	10
C	C0	AL	AM	1 m	863523	10
x2	ALSJ	PP	BM		611261	300

** Na zamówienie/ Available on request/ Auf Anfrage verfügbar

AL ALUMINIUM ANODOWANE
ANODIZED ALUMINIUM
ELOXIERTES ALUMINIUM

PVC



(BM) Produkt barwiony w masie - matowy/ Full body coloured product - matt/ Einfarbiges Produkt - matt, **(AM)** Produkt anodowane - matowy/ Anodised product - matt/ Eloxiertes Produkt - matt

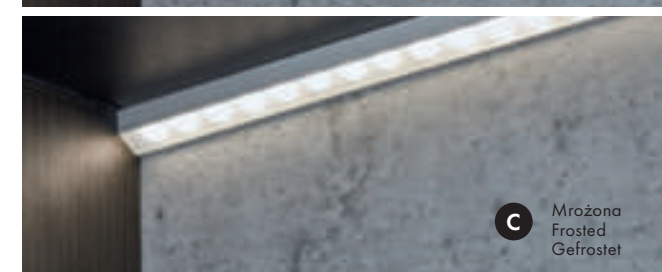
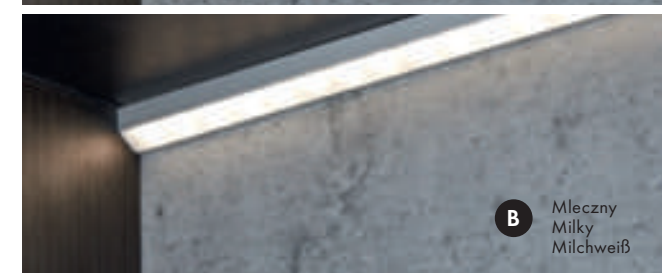
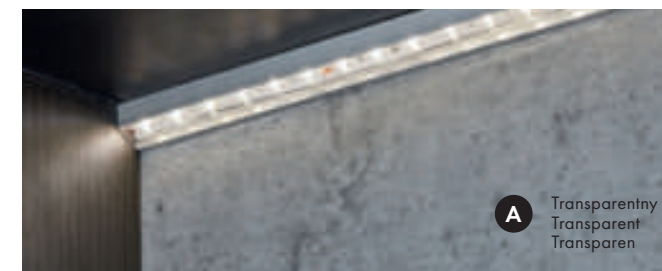
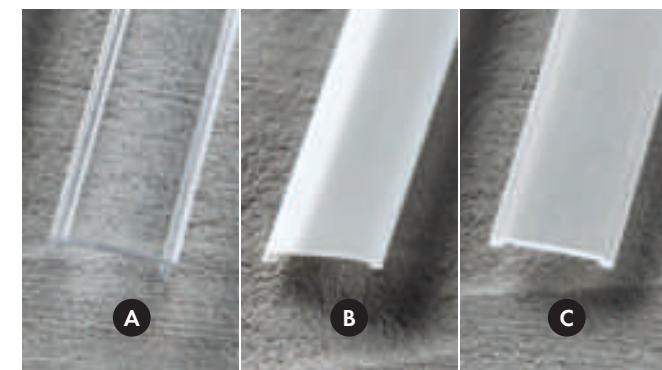
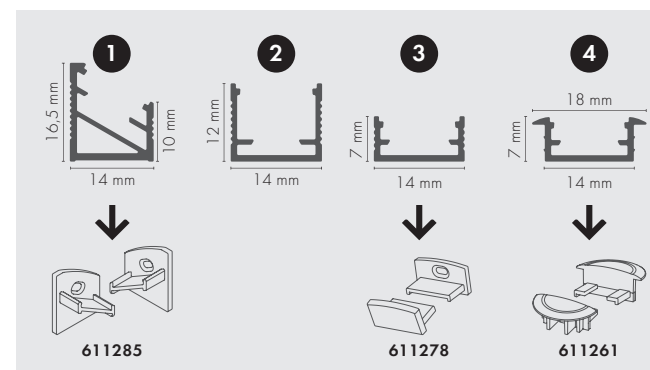

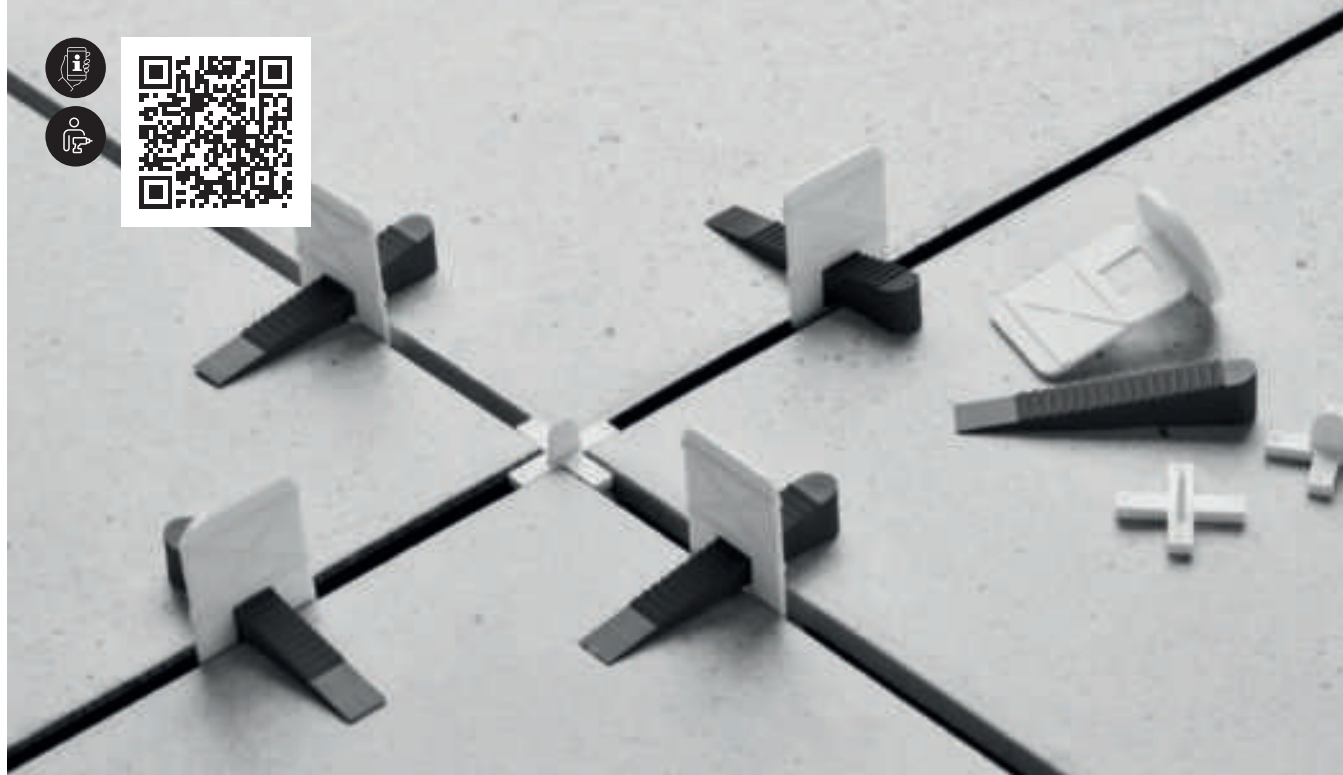

SYSTEM DO MONTAŻU PŁYTEK
SYSTEM FOR TILES INSTALLATION
SYSTEM ZUR FLIESENVERLEGUNG

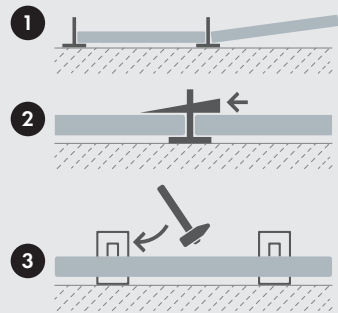

- Do zastosowania przy montażu płytek o grubości od 6 do 12 mm.
- Skraca czas i podnosi wydajność układania płytek.
- Zapobiega przesuwniu się płytek podczas układania oraz schnięcia kleju.
- Bez użycia dodatkowych narzędzi.
- Łatwy w montażu na każdym poziomie umiejętności.

- Use when assembling tiles of 6-12 mm thickness
- Shortens the time of assembly and increases the working efficiency.
- Avoids tiles moving during and after the assembly.
- No need in additional tools.
- Easy assembly even for laymen.

- Verwendung bei Fliesen mit einer Stärke von 6-12 mm.
- Verkürzt die Verlegezeit und erhöht die Arbeitseffizienz.
- Verhindert das Verrutschen der Fliesen während und nach der Verlegung.
- Kein zusätzliches Werkzeug erforderlich.
- Einfache Anwendung, auch für Laien.

	622540	30	30	30	
	622588	60	-	25	
	622595	200	100	1	
	633829	300	-	1	

MULTISPACER

I / T / X

System akcesoriów służący do układania płytek ceramicznych. Dwa multispacery I można połączyć, uzyskując w razie potrzeby podwójną grubość.

A system of accessories used for laying ceramic tiles. Two multispacers can be connected to achieve double thickness if needed.

Ein System von Zubehörteilen zum Verlegen von Keramikfliesen. Zwei Multispacer können miteinander verbunden werden, um bei Bedarf doppelte Dicke zu erreichen.

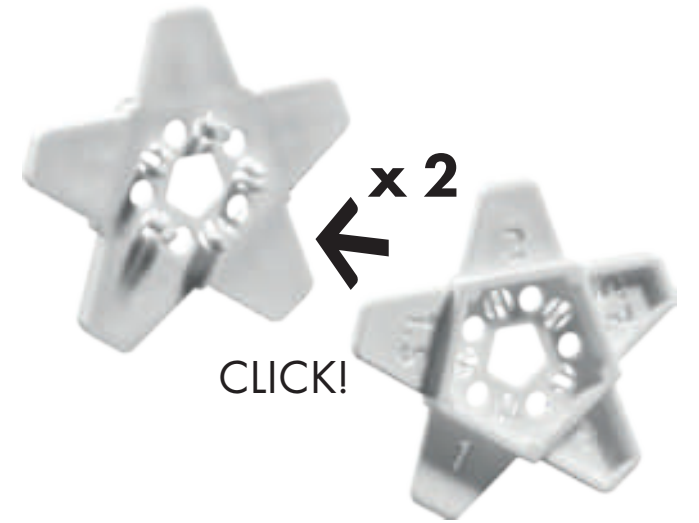

MULTISPACER I

1 / 1,5 / 2 / 2,5 / 3 mm
 2 / 3 / 4 / 5 / 6 mm x 2



MULTISPACER T

1 / 2 / 3 / 4 / 5 mm



MULTISPACER X

1 / 2 / 3 / 4 / 5 mm



	699344	50	40

	826115	20	40

	699382	20	30

**KRZYŻYKI DO GLAZURY UNIWERSALNE
UNIVERSAL TILE SPACERS
UNIVERSELLE FLIESENKREUZE**

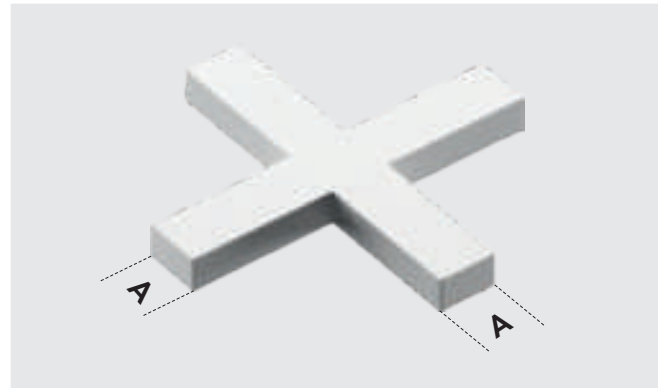

1 mm	644771	300	100
1,5 mm	644788	200	100
2 mm	644801	200	100
2,5 mm	644818	100	100
3 mm	644825	100	100
3,5 mm	644832	75	100
4 mm	644849	75	100
5 mm	644856	75	50
6 mm	644863	30	50
8 mm	644870	25	50
10 mm	644887	20	50

**KRZYŻYKI DO GLAZURY Z DYSTANSEM
TILE SPACERS WITH DISTANCE
FLIESENKREUZE MIT ABSTAND**

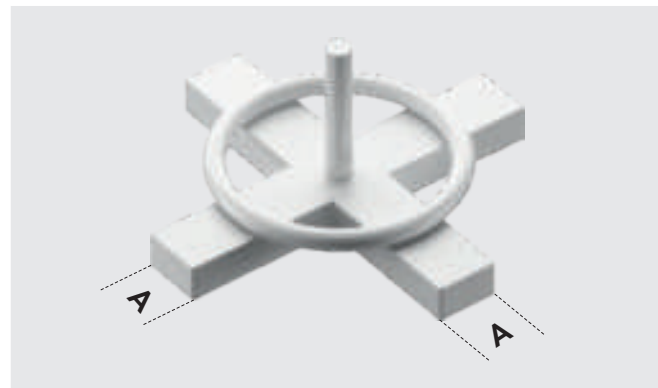

1 mm	640070	200	100
1,5 mm	640087	150	100
2 mm	640094	100	100
2,5 mm	640100	75	100
3 mm	640117	50	100
3,5 mm	640124	50	100

**KRZYŻYKI DO GLAZURY Z UCHEM
TILE SPACERS WITH HANDLE
FLIESENKREUZE MIT GRIFF**

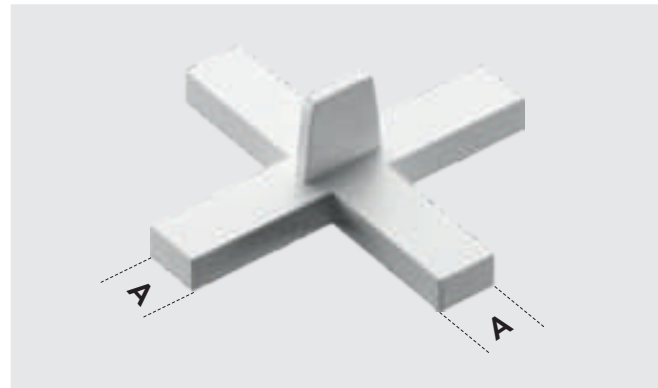

4 mm	860102***	75	100
5 mm	860119***	75	50
6 mm	860126***	30	50
8 mm	860133***	25	50

*** Outlet

**TEOWNIKI DO CEGŁY KLINKIEROWEJ
T-SHAPED SPACERS
T-TRÄGER FÜR KLINKERZIEGEL**

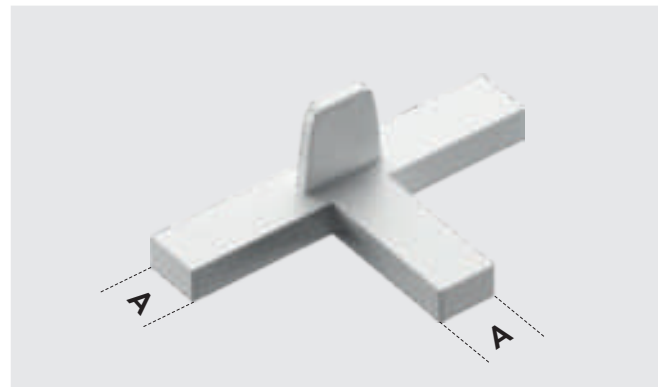

3 mm	644979	100	100
3 mm	860249***	100	100
4 mm	644986	100	100
5 mm	644993	100	100
5 mm	860263***	100	100
6 mm	645006	40	50
6 mm	860171***	40	50
8 mm	645013	30	50
10 mm	645020	25	50

*** Outlet

**KLINY DO CEGŁY KLINKIEROWEJ
WEDGE SHAPED TILE SPACERS
ABSTANDSKEILE FÜR KLINKERZIEGEL**



	860157	100	100
	860164	50	100

**TRZPIEŃ WCISKANY CEZAR
CEZAR PRESS STUD
STECKBOLZEN CEZAR**



601866***		25	150

*** Outlet

**TRZPIEŃ CEZAR
CEZAR STUD
BOLZEN CEZAR**

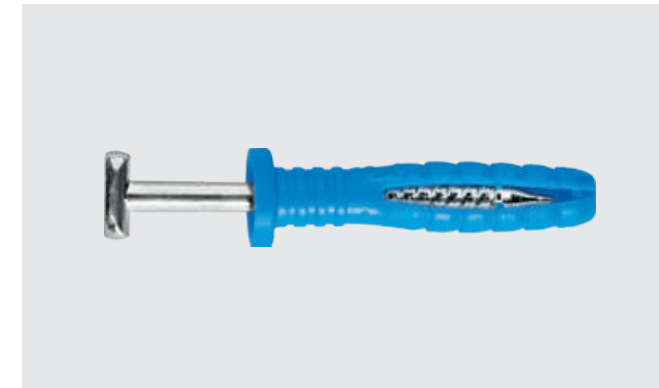

817366**		10	200

** Na zamówienie/ On request/ Auf Anfrage

**ŁĄCZNIK KĄTOWY PŁASKI
FLAT CORNER CONNECTOR
FLACHER ECKVERBINDER**



601873		10	300



PSP/ PSP 12

ALUMINIUM I MOSIĄDZ/ALUMINIUM AND BRASS/ ALUMINIUM UND MESSING

STAL NIERDZEWNA/ STAINLESS STEEL/ EDELSTAHL

PSP SN

AL ALUMINIUM ANODOWANE
ANODIZED ALUMINIUM
ELOXIERTES ALUMINIUM

MS MOSIĄDZ
BRASS
MESSING

SN STAL NIERDZEWNA
STAINLESS STEEL
EDELSTAHL

PSP	ZC0	AL	AM	2,5 m	829215	10
	P	AL	SP	2,5 m	804601**	10
	N	AL	S	1 m	804205**	10
	N	AL	S	2 m	804229**	10
	N	AL	S	2,5 m	804236	10
	C0	AL	AM	1 m	804311	10
	C0	AL	AM	2 m	804519**	10
	C0	AL	AM	2,5 m	804267	10
	C32	AL	AM	1 m	804335**	10
	C32	AL	AM	2,5 m	804281	10
	C23	AL	AM	1 m	804328**	10
	C23	AL	AM	2,5 m	804540	10
N	SN	PB	2,5 m	860942**	10	
PSP12	ZC0	AL	AM	2,5 m	829222	10
	C0	AL	AM	2,5 m	862861	10
	C32	AL	AM	2,5 m	862953**	10
	C23	AL	AM	2,5 m	862946**	10

** Na zamówienie/ On request/ Auf Anfrage *** Outlet

(AM) Produkt anodowany - matowy/ Anodised product - matt/ Eloxiertes Produkt - matt, (SP) Polerowane aluminium lub mosiądz/ Polished aluminium or brass/ Poliertes Aluminium oder Messing, (S) Wykończenie surowe/ Raw finish/ Rohe Oberfläche, (PB) Stal nierdzewna naturalna/ Natural stainless steel/ Edelstahl natürlich, (CP) Chrom polysk/ Chrome gloss/ Chrom glänzend,

ZET

ALUMINIUM I MOSIĄDZ/ALUMINIUM AND BRASS/ ALUMINIUM UND MESSING

STAL NIERDZEWNA/ STAINLESS STEEL/ EDELSTAHL

ZET (SN)

AL ALUMINIUM ANODOWANE
ANODIZED ALUMINIUM
ELOXIERTES ALUMINIUM

MS MOSIĄDZ
BRASS
MESSING

SN STAL NIERDZEWNA
STAINLESS STEEL
EDELSTAHL

ZET	N	AL	S	1 m	803208**	10
	N	AL	S	2 m	803222	10
	N	AL	S	2,5 m	803239	10
	N	AL	S	3 m	803246	10
	ZC0	AL	AM	2,5 m	829390	10
	C0	AL	AM	2 m	803321**	10
	C0	AL	AM	2,5 m	803338	10
	C0	AL	AM	3 m	803345**	10
	C23	AL	AM	1 m	803352**	10
	C23	AL	AM	2,5 m	803383	10
	N	MS	S	1 m	813207***	10
	N	MS	S	2,5 m	813238**	10
N	SN	PB	2,5 m	860935	10	

** Na zamówienie/ On request/ Auf Anfrage *** Outlet

AL ALUMINIUM ANODOWANE
ANODIZED ALUMINIUM
ELOXIERTES ALUMINIUM

MS MOSIĄDZ
BRASS
MESSING

SN STAL NIERDZEWNA
STAINLESS STEEL
EDELSTAHL



ZETPL

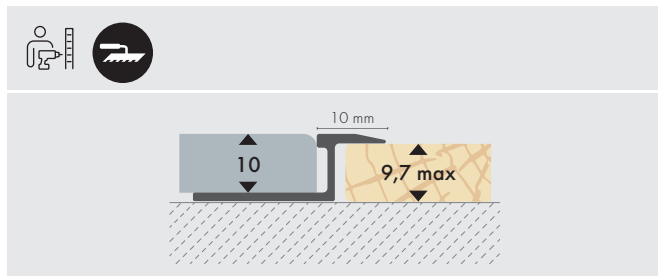

AL ALUMINIUM ANODOWANE
ANODIZED ALUMINIUM
ELOXIERTES ALUMINIUM

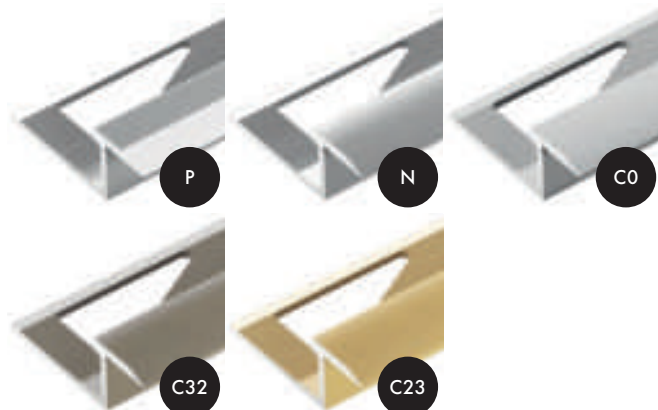

MS MOSIADZ
BRASS
MESSING



ZETPL

P	AL	SP	1 m	803505**	10	
P	AL	SP	2 m	803529**	10	
P	AL	SP	2,5 m	803536**	10	
P	AL	SP	3 m	803543**	10	
N	AL	S	1 m	803406	10	
N	AL	S	2 m	803420	10	
N	AL	S	2,5 m	803437	10	
N	AL	S	3 m	803444**	10	
CO	AL	AM	1 m	803604**	10	
CO	AL	AM	2 m	803628**	10	
CO	AL	AM	2,5 m	803635	10	
CO	AL	AM	3 m	803642**	10	
C32	AL	AM	2,5 m	805257**	10	
C23	AL	AM	2,5 m	803734	10	
N	MS	S	1 m	813405**	10	
N	MS	S	2 m	813429**	10	
N	MS	S	2,5 m	813436**	10	
N	AL	S	2,5 m	803765**	10	
CO	AL	AM	2,5 m	803758	10	
C23	AL	AM	2,5 m	805981**	10	

** Na zamówienie/ Available on request/ Auf Anfrage verfügbar *** Outlet



ZETPLP

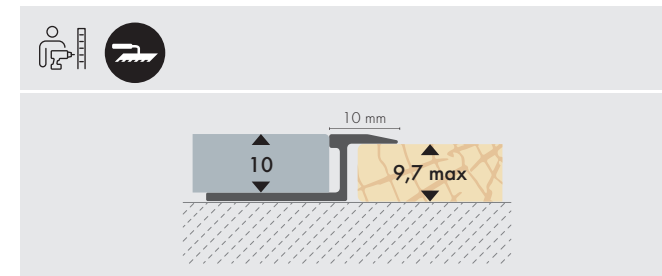

ZETPLP

N	AL	S	2,5 m	803765**	10
CO	AL	AM	2,5 m	803758	10
C23	AL	AM	2,5 m	805981**	10

AL ALUMINIUM ANODOWANE
ANODIZED ALUMINIUM
ELOXIERTES ALUMINIUM



PS 2

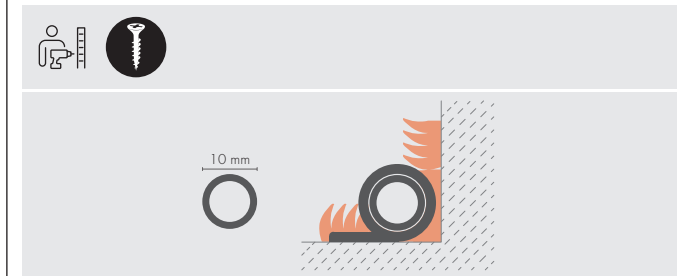

CO	AL	AM	1,2 m	824067	10
C32	AL	AM	1,2 m	806438	10
C23	AL	AM	1,2 m	824074**	10
C34	AL	AM	1,2 m	824104**	10

** Na zamówienie/ On request/ Auf Anfrage

AL ALUMINIUM ANODOWANE
ANODIZED ALUMINIUM
ELOXIERTES ALUMINIUM





ZETOW/ ZETOW 12

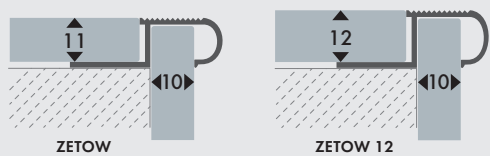

	AL	MS				
ZETOW	N	AL	S	1 m	803109**	10
ZETOW	N	AL	S	2 m	803123**	10
ZETOW	N	AL	S	2,5 m	803130	10
ZETOW	ZC0	AL	AM	2,5 m	829239	10
ZETOW	C0	AL	AM	2,5 m	840036	10
ZETOW	C23	AL	AM	2,5 m	840081**	10
ZETOW	N	MS	S	2 m	813122**	10
ZETOW12	ZC0	AL	AM	2,5 m	829246	10

** Na zamówienie/ On request/ Auf Anfrage

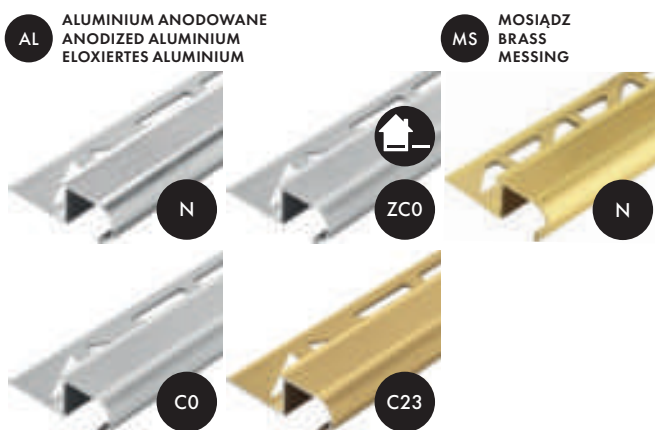

(S) Wykończenie surowe/ Raw finish/ Rohe Oberfläche, (AM) Produkt anodowany - matowy/ Anodised product - matt/ Eloxiertes Produkt - matt, (SP) Polerowane aluminium lub mosiądz/ Polished aluminium or brass/ Poliertes Aluminium oder Messing.



CL

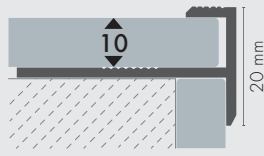

	AL	SP				
P	AL	SP	2,5 m	804151		10
N	AL	S	1 m	804106**		10
N	AL	S	2 m	804120**		10
N	AL	S	2,5 m	804137		10
N	AL	S	3 m	804144**		10
ZC0	AL	AM	2,5 m	829208		10
C0	AL	AM	1 m	804816		10
C0	AL	AM	2 m	805011		10
C0	AL	AM	2,5 m	804168		10
C0	AL	AM	3 m	805219**		10
C32	AL	AM	3 m	898440**		10
C23	AL	AM	1 m	804823**		10
C23	AL	AM	2 m	805028**		10
C23	AL	AM	2,5 m	804175**		10

** Na zamówienie/ On request/ Auf Anfrage

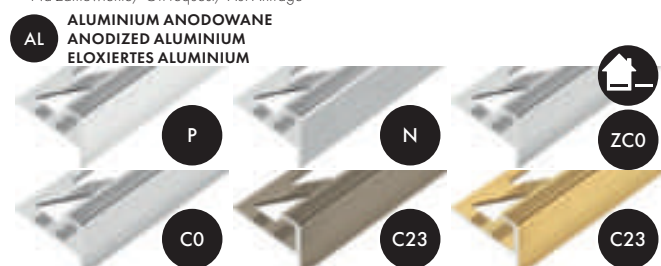

Z3LVT/ Z5LVT

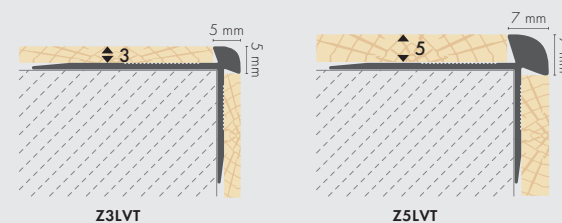

	AL	AM				
Z3LVT	C0	AL	AM	0,9 m	827440**	10
	C0	AL	AM	2,7 m	807312	10
Z5LVT	C0	AL	AM	0,9 m	827501**	8
	C0	AL	AM	2,7 m	807329	10

** Na zamówienie/ On request/ Auf Anfrage



W3LVT/ W5LVT

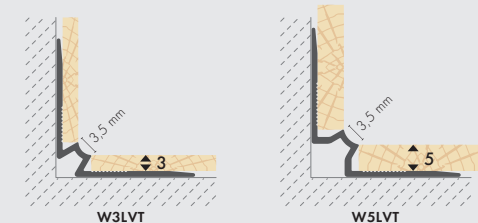

	AL	AM				
W3LVT	C0	AL	AM	0,9 m	827426	12
	C0	AL	AM	2,7 m	807299	10
W5LVT	C0	AL	AM	0,9 m	827433	12
	C0	AL	AM	1,35 m	820953	10
	C0	AL	AM	2,7 m	807305	10





CL3LVT/ CL5LVT

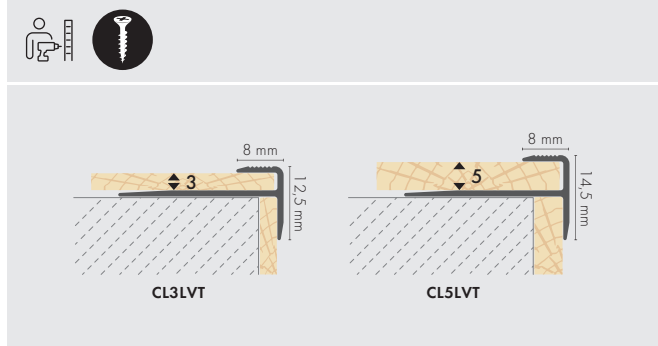

	CO	AL	AM	0,9 m	827402	12
CL3LVT	CO	AL	AM	2,7 m	807268	10
	CO	AL	AM	0,9 m	827419	12
CL5LVT	CO	AL	AM	1,35 m	820885	10
	CO	AL	AM	2,7 m	807275	10

AL ALUMINIUM ANODOWANE
ANODIZED ALUMINIUM
ELOXIERTES ALUMINIUM



RYFL T23

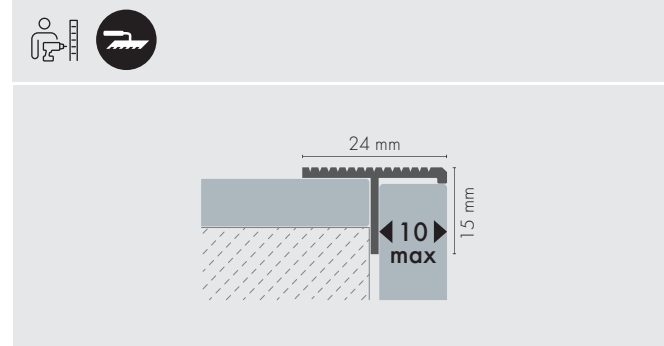

N	AL	S	1 m	803000**	10
N	AL	S	2,5 m	803031	10
N	MS	S	1 m	813009***	10

** Na zamówienie/ On request/ Auf Anfrage *** Outlet

AL ALUMINIUM ANODOWANE
ANODIZED ALUMINIUM
ELOXIERTES ALUMINIUM

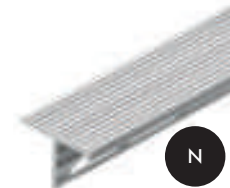

MS MOSIĄDZ
BRASS
MESSING

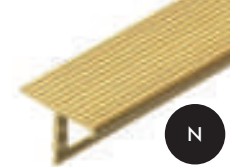

(AM) Produkt anodowany - matowy/ Anodised product - matt/ Eloxiertes Produkt - matt, (S) Wykończenie surowe/ Raw finish/ Rohe Oberfläche



PODKG

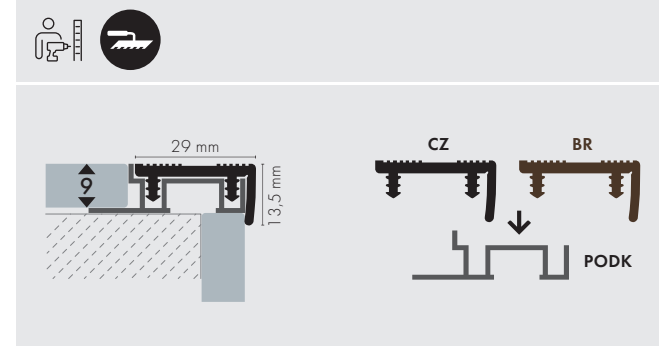

PODK	N	AL	S	2,50	845031**	10
PODKGBR	N	AL	S	2,50	844928**	10
PODKZGCZ	N	AL	S	2,50	844935	10

** Na zamówienie/ On request/ Auf Anfrage

AL ALUMINIUM ANODOWANE
ANODIZED ALUMINIUM
ELOXIERTES ALUMINIUM

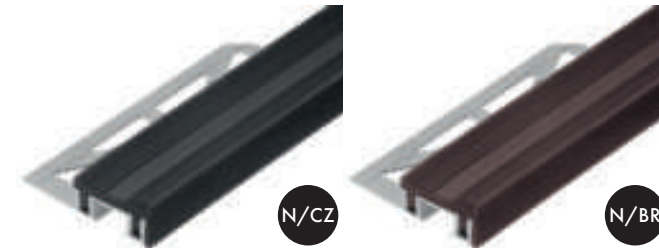

PODKZGCZ

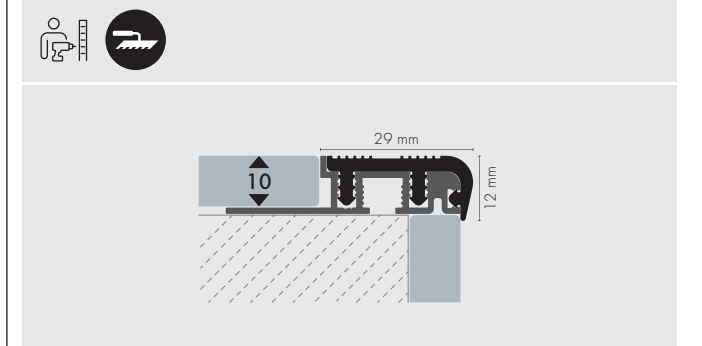

PODKZGCZ	N	AL	S	2,00	826801**	10
----------	---	----	---	------	----------	----

** Na zamówienie/ On request/ Auf Anfrage

AL ALUMINIUM ANODOWANE
ANODIZED ALUMINIUM
ELOXIERTES ALUMINIUM

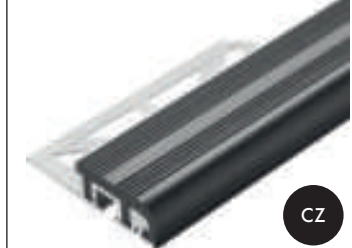



20 P

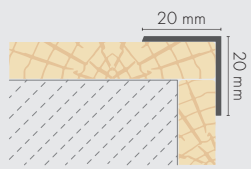

Code	Material	Finish	Length	Product Code	Quantity
C0	AL	AM	1,35 m	868825	10
C0	AL	AM	2,5 m	826733***	10
C32	AL	AM	1,35 m	868849	10
C23	AL	AM	1,35 m	868832**	10
DB	AL	OM	1,35 m	892110**	10
DW	AL	OM	1,35 m	893322**	10
SR	AL	OM	1,35 m	804892**	10
DO	AL	OM	1,35 m	804878**	10
DJ	AL	OM	1,35 m	860287	10
DG	AL	OM	1,35 m	893315**	10
DN	AL	OM	1,35 m	860294**	10
DC	AL	OM	1,35 m	804854**	10
DZ	AL	OM	1,35 m	860317**	10
D	AL	OM	1,35 m	868719	10
B	AL	OM	1,35 m	868726**	10
DR	AL	OM	1,35 m	868771***	10
RZ	AL	OM	1,35 m	868740**	10
R	AL	OM	1,35 m	868795***	10
T	AL	OM	1,35 m	892219**	10
V	AL	OM	1,35 m	868764**	10
RC	AL	OM	1,35 m	800276***	10

** Na zamówienie/ On request/ Auf Anfrage *** Outlet

(AM) Produkt anodowany - matowy/ Anodised product - matt/ Eloxiertes Produkt - matt, (OM) Okleina mat/ Foil with wood finishes/ Folie mit Holzoptik, (S) Wykończenie surowe/ Raw finish/ Rohe Oberfläche

AL ALUMINIUM ANODOWANE
ANODIZED ALUMINIUM
ELOXIERTES ALUMINIUM

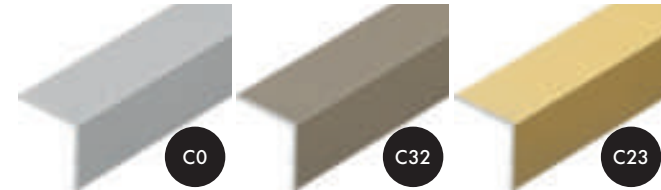

MS MOSIADZ
BRASS
MESSING

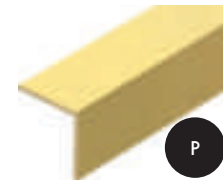

AL AC4 ALUMINIUM LAMINOWANE
LAMINATED ALUMINIUM
LAMINIERTES ALUMINIUM



20 R

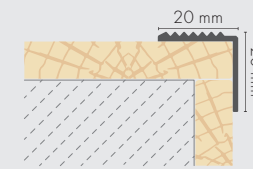

Code	Material	Finish	Length	Product Code	Quantity
N	AL	S	1 m	833670	10
N	AL	S	2 m	833878	10
C0	AL	AM	0,9 m	877612***	10
C0	AL	AM	1 m	833618	10
C0	AL	AM	2 m	833816	10
C32	AL	AM	1 m	833632	10
C32	AL	AM	2 m	833830	10
C23	AL	AM	0,9 m	877629***	10
C23	AL	AM	1 m	833625	10
C23	AL	AM	2 m	833823	10

*** Outlet

AL ALUMINIUM ANODOWANE
ANODIZED ALUMINIUM
ELOXIERTES ALUMINIUM

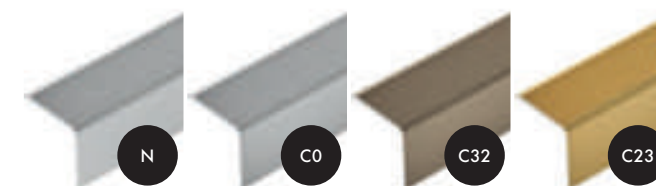

30 R

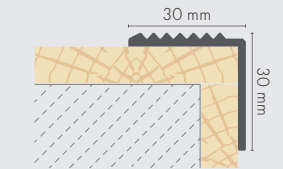

Code	Material	Finish	Length	Product Code	Quantity
C0	AL	AM	0,9 m	877810***	6
C0	AL	AM	1 m	833717	6
C0	AL	AM	2 m	833915	5
C32	AL	AM	1 m	833731	6
C32	AL	AM	2 m	833939	5
C23	AL	AM	1 m	833724	6
C23	AL	AM	2 m	833922	5
C34	AL	AM	1 m	833755**	6
C34	AL	AM	2 m	833953**	5

** Na zamówienie/ On request/ Auf Anfrage *** Outlet

AL ALUMINIUM ANODOWANE
ANODIZED ALUMINIUM
ELOXIERTES ALUMINIUM





30 RR

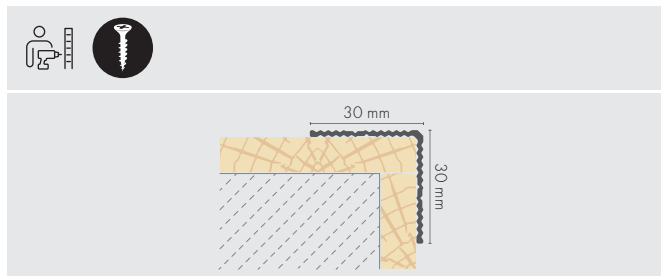

CO	AL	AM	1 m	894411***	6
CO	AL	AM	2 m	805097***	5
C23	AL	AM	1 m	850530***	6
C23	AL	AM	2 m	850738***	5

*** Outlet

AL ALUMINIUM ANODOWANE
ANODIZED ALUMINIUM
ELOXIERTES ALUMINIUM

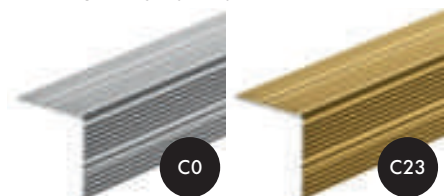

LSS

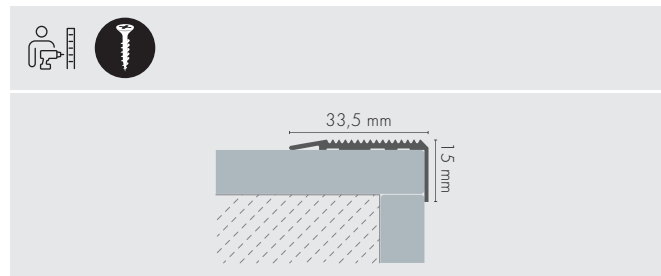

CO	AL	AM	0,9 m	877216***	12
CO	AL	AM	1,8 m	877315***	10
C32	AL	AM	2 m	832833	10
P	MS	SP	1,1 m	870057***	10
P	MS	SP	1,8 m	804946**	10

** Na zamówienie/ On request/ Auf Anfrage *** Outlet

AL ALUMINIUM ANODOWANE
ANODIZED ALUMINIUM
ELOXIERTES ALUMINIUM

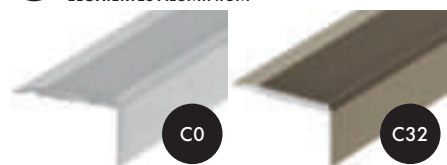

MS MOSIĄDZ
BRASS
MESSING



(AM) Produkt anodowany - matowy/ Anodised product - matt/ Eloxiertes Produkt - matt, **(SP)** Polerowane aluminium lub mosiądz/ Polished aluminium or brass/ Poliertes Aluminium oder Messing, **(AP)** Produkt anodowany - połysk/ Anodised product - gloss/ Eloxiertes Produkt - glänzend



LSR

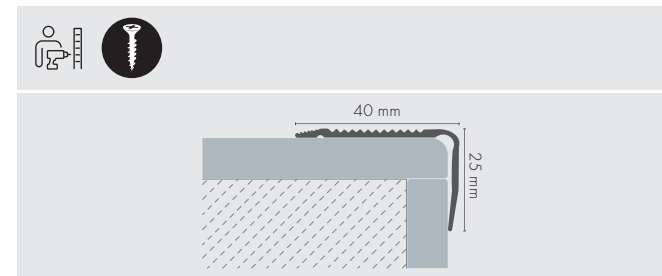

C34	AL	AM	1 m	859359***	10
-----	----	----	-----	-----------	----

*** Outlet

AL ALUMINIUM ANODOWANE
ANODIZED ALUMINIUM
ELOXIERTES ALUMINIUM

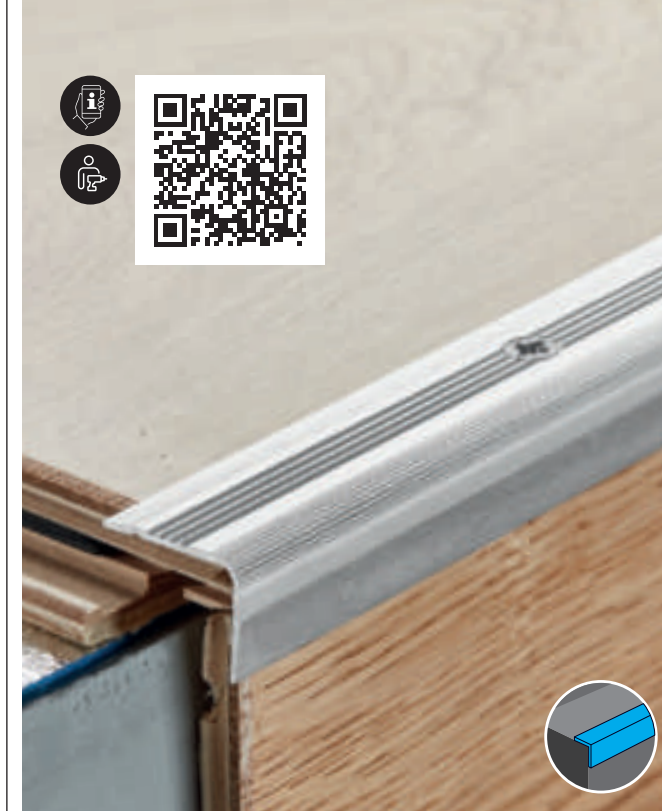

LSR 24

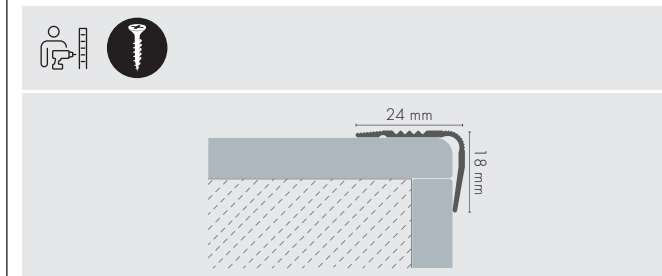

ECOS	AL	AP	1,1 m	828713**	10
CO	AL	AM	1,1 m	825705**	10
C51	AL	AM	1,1 m	828706**	10

** Na zamówienie/ On request/ Auf Anfrage

AL ALUMINIUM ANODOWANE
ANODIZED ALUMINIUM
ELOXIERTES ALUMINIUM



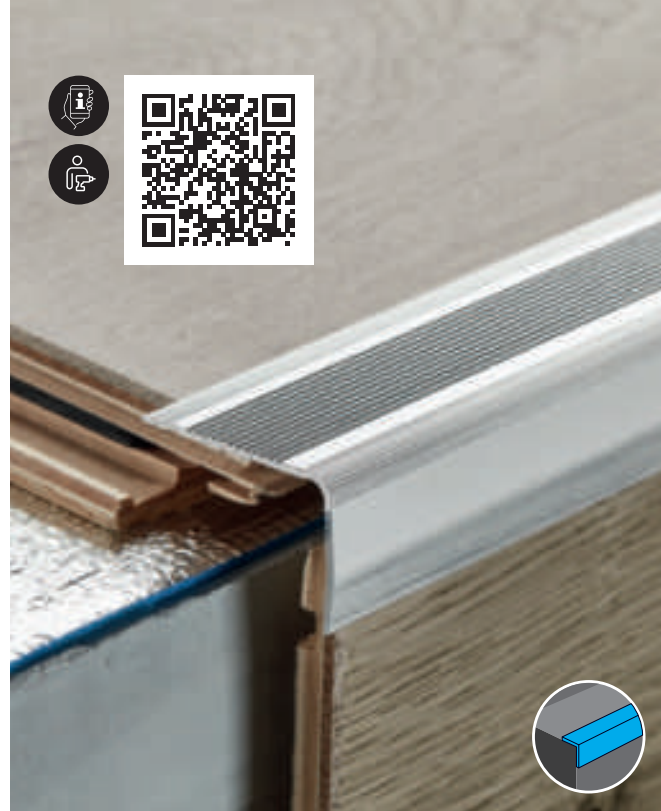

LSR 36

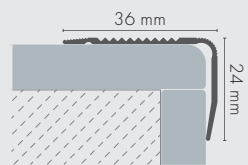

ECOS	AL	AP	1,1 m	829253	10
ECOS	AL	AP	2,3 m	838804	10
C0	AL	AM	1,1 m	825699**	10
C0	AL	AM	2,3 m	838781	10
C51	AL	AM	1,1 m	829260	10
C51	AL	AM	2,3 m	838798	10

** Na zamówienie/ On request/ Auf Anfrage



LSSZG

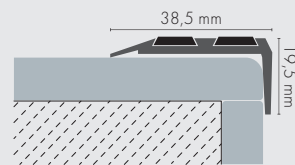

C0	AL	AM	1 m	836510	10
C0	AL	AM	2 m	836718	10
C0	AL	AM	2,5 m	857515***	10
C0	AL	AM	2,7 m	836817	10
C0	AL	AM	3 m	836916***	10
C32	AL	AM	1 m	836534	10
C32	AL	AM	2 m	836732	10
C32	AL	AM	2,7 m	829611	10
C23	AL	AM	1 m	836527	10
C23	AL	AM	2 m	836725**	10
C23	AL	AM	2,7 m	836824	10
C34	AL	AM	0,9 m	877056***	10

** Na zamówienie/ On request/ Auf Anfrage *** Outlet

AL ALUMINIUM ANODOWANE
ANODIZED ALUMINIUM
ELOXIERTES ALUMINIUM

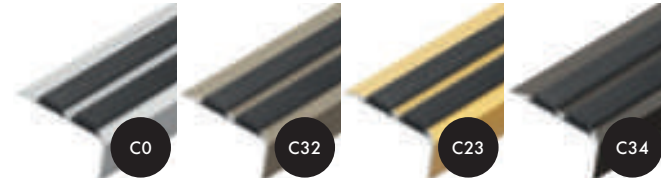

LSS 44

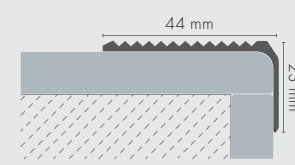

C0	AL	AM	2 m	826122***	10
C0	AL	AM	2,7 m	819360***	10
C23	AL	AM	2,7 m	819384***	10

*** Outlet

AL ALUMINIUM ANODOWANE
ANODIZED ALUMINIUM
ELOXIERTES ALUMINIUM

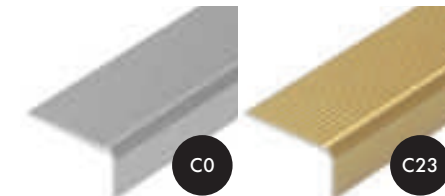

LSSR

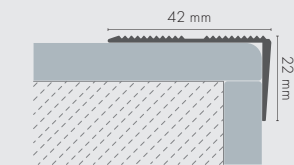

C0	AL	AM	0,9 m	878015***	10
C0	AL	AM	1 m	838019	10
C0	AL	AM	2 m	838118	10
C0	AL	AM	3 m	838217***	10
C32	AL	AM	1 m	838033	10
C32	AL	AM	2 m	838132**	10
C32	AL	AM	3 m	838231***	10
C23	AL	AM	0,9 m	878022***	10
C23	AL	AM	1 m	838026	10
C23	AL	AM	2 m	838125	10
C23	AL	AM	3 m	838224***	10

** Na zamówienie/ On request/ Auf Anfrage *** Outlet

AL ALUMINIUM ANODOWANE
ANODIZED ALUMINIUM
ELOXIERTES ALUMINIUM

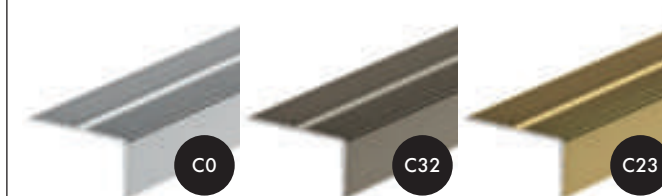

AL ALUMINIUM ANODOWANE
ANODIZED ALUMINIUM
ELOXIERTES ALUMINIUM

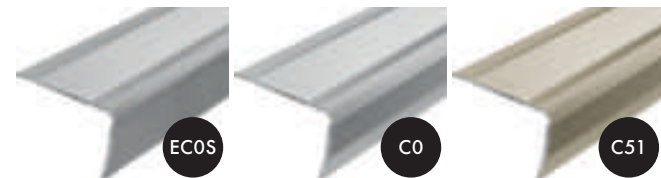



LSW 10

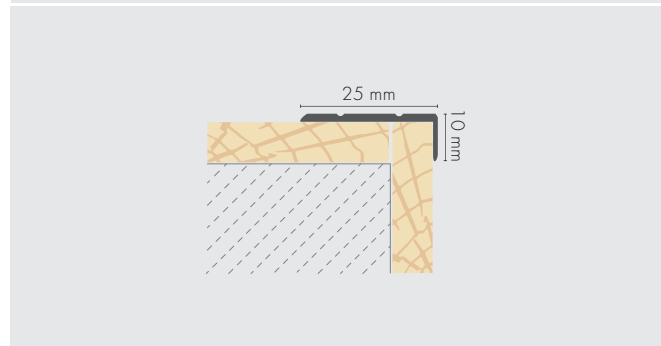

AL AC4 ALUMINIUM LAMINOWANE
LAMINATED ALUMINIUM
LAMINIERTES ALUMINIUM



AL ALUMINIUM ANODOWANE
ANODIZED ALUMINIUM
ELOXIERTES ALUMINIUM

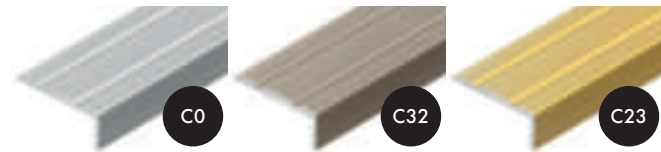

MS MOSIADZ
BRASS
MESSING

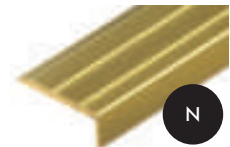

C0	AL	AM	0,9 m	877414***	12
C0	AL	AM	1 m	835414	12
C0	AL	AM	2 m	835612	10
C32	AL	AM	1 m	835438	12
C32	AL	AM	2 m	835636**	10
C23	AL	AM	0,9 m	877421***	12
C23	AL	AM	1 m	835421	12
C23	AL	AM	2 m	835629	10
C23	AL	AM	2,5 m	858734***	10
N	MS	S	1 m	800535***	10
C0	AL	AM	1 m	881329	12
C0	AL	AM	1,35 m	814464**	10
C0	AL	AM	2 m	881527**	10
C0	AL	AM	2,7 m	814471	10
C32	AL	AM	1 m	894497**	12
C32	AL	AM	1,35 m	814501**	10
C32	AL	AM	2 m	894503**	10
C32	AL	AM	2,7 m	814518	10
C23	AL	AM	1 m	881336	12
C23	AL	AM	1,35 m	814488**	10
C23	AL	AM	2 m	881534	10
C23	AL	AM	2,7 m	814495	10
C34	AL	AM	1,35 m	814525**	10
C34	AL	AM	2,7 m	814532**	10
DB	AL	OM	1,35 m	814563**	10
DB	AL	OM	2,7 m	814570**	10
DW	AL	OM	1,35 m	814785	10
DW	AL	OM	2,7 m	814792	10
DO	AL	OM	1,35 m	814686**	10
DO	AL	OM	2,7 m	814693	10
DJ	AL	OM	1,35 m	814648	10
DJ	AL	OM	2,7 m	814655	10
DG	AL	OM	1,35 m	814600**	10
DG	AL	OM	2,7 m	814617**	10
DN	AL	OM	1,35 m	814662***	10
DN	AL	OM	2,7 m	814679	10
DH	AL	OM	1,35 m	814624	10
DH	AL	OM	2,7 m	814631	10
DC	AL	OM	1,35 m	814587**	10
DC	AL	OM	2,7 m	814594**	10
DS	AL	OM	1,35 m	814747**	10
DS	AL	OM	2,7 m	814754**	10
DZ	AL	OM	1,35 m	814808**	10
DZ	AL	OM	2,7 m	814815**	10
D	AL	OM	1,35 m	814549	10
D	AL	OM	2,7 m	814556	10
B	AL	OM	1,35 m	814440**	10
B	AL	OM	2,7 m	814457**	10
DP	AL	OM	1,35 m	814709**	10
DP	AL	OM	2,7 m	814716**	10
RZ	AL	OM	1,35 m	814860**	10
RZ	AL	OM	2,7 m	814877**	10
R	AL	OM	1,35 m	814846**	10

R	AL	OM	2,7 m	814853**	10
T	AL	OM	1,35 m	814884**	10
T	AL	OM	2,7 m	814891**	10
V	AL	OM	1,35 m	814907**	10
V	AL	OM	2,7 m	814914**	10

C0	AL	AM	1 m	800115	10
C0	AL	AM	2 m	800146	10
C23	AL	AM	1 m	800085	10
C23	AL	AM	2 m	800092	10

** Na zamówienie/ On request/ Auf Anfrage *** Outlet



LSW 20

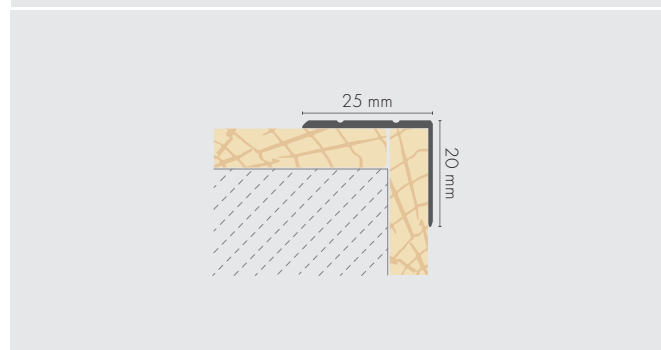

AL AC4 ALUMINIUM LAMINOWANE
LAMINATED ALUMINIUM
LAMINIERTES ALUMINIUM

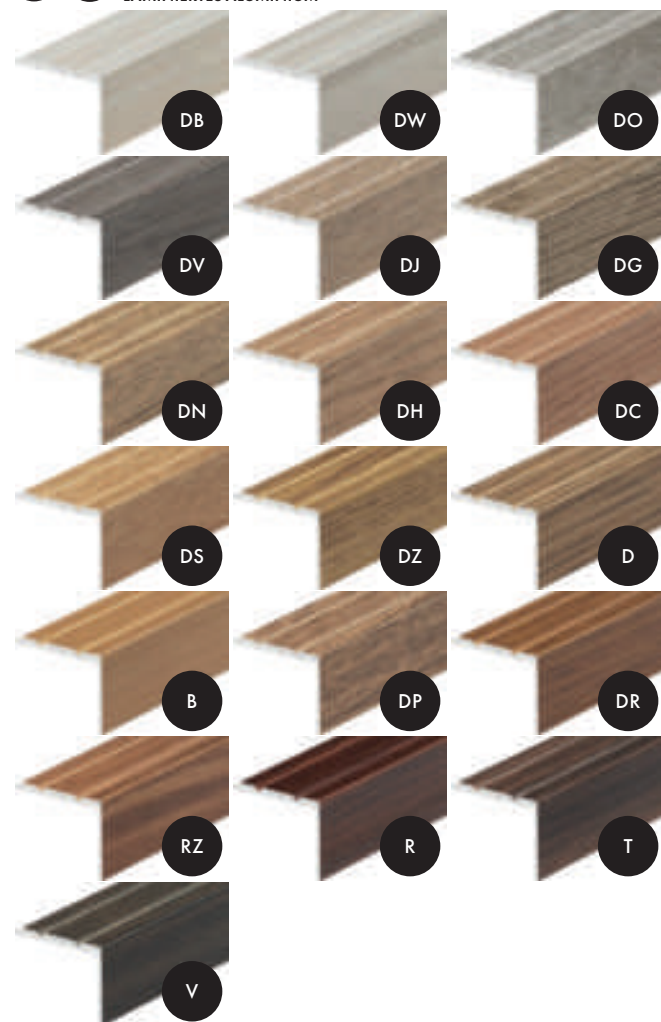

AL ALUMINIUM ANODOWANE
ANODIZED ALUMINIUM
ELOXIERTES ALUMINIUM

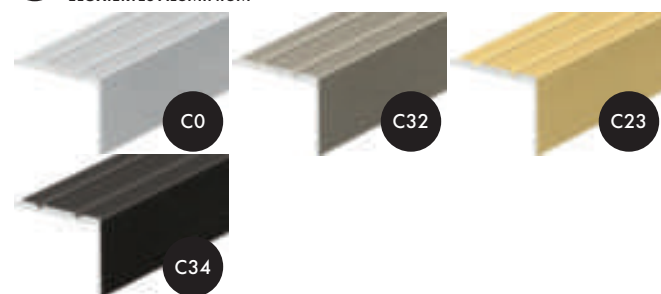

C0	AL	AM	0,9 m	851827***	12
C0	AL	AM	1 m	851926	12
C0	AL	AM	2 m	852121	10
C0	AL	AM	2,5 m	858826***	10
C0	AL	AM	2,7 m	808531	10
C32	AL	AM	1 m	851940	12
C32	AL	AM	2 m	852145**	12
C23	AL	AM	0,9 m	851834***	10
C23	AL	AM	1 m	851933	12
C23	AL	AM	2,00	852138**	10
C23	AL	AM	2,50	858833***	10
C34	AL	AM	1 m	851964**	12
C0	AL	AM	1,35 m	814976	10
C32	AL	AM	1 m	894541***	12
C32	AL	AM	1,35 m	815010**	10
C32	AL	AM	2 m	894558**	10
C32	AL	AM	2,7 m	815027**	10
C23	AL	AM	1,35 m	814990**	10
C34	AL	AM	1,35 m	815034**	10
DB	AL	OM	1,35 m	815072**	10
DB	AL	OM	2,7 m	815089**	10
DW	AL	OM	1,35 m	815294**	10
DW	AL	OM	2,7 m	815300**	10
DO	AL	OM	1,35 m	815195	10
DO	AL	OM	2,7 m	815201	10
DV	AL	OM	2,7 m	815287***	10
DJ	AL	OM	1,35 m	815157	10
DJ	AL	OM	2,7 m	815164	10
DG	AL	OM	1,35 m	815119**	10
DG	AL	OM	2,7 m	815126**	10
DN	AL	OM	1,35 m	815171**	10
DN	AL	OM	2,7 m	815188**	10
DH	AL	OM	1,35 m	815133	10
DH	AL	OM	2,7 m	815140	10
DC	AL	OM	1,35 m	815096**	10
DC	AL	OM	2,7 m	815102**	10
DS	AL	OM	1,35 m	815256**	10
DS	AL	OM	2,7 m	815263**	10
DZ	AL	OM	1,35 m	815317**	10
DZ	AL	OM	2,7 m	815355**	10
D	AL	OM	1,35 m	815058	10
D	AL	OM	2,7 m	815065**	10
B	AL	OM	1,35 m	814945**	10
B	AL	OM	2,7 m	814952**	10
DP	AL	OM	1,35 m	815218**	10
DP	AL	OM	2,7 m	815225**	10
RZ	AL	OM	1,35 m	815416**	10
RZ	AL	OM	2,7 m	815454**	10
R	AL	OM	1,35 m	815386**	10
R	AL	OM	2,7 m	815393**	10
T	AL	OM	1,35 m	815461**	10
T	AL	OM	2,7 m	815478**	10
V	AL	OM	1,35 m	815485**	10
V	AL	OM	2,7 m	815492**	10

** Na zamówienie/ On request/ Auf Anfrage *** Outlet



KP

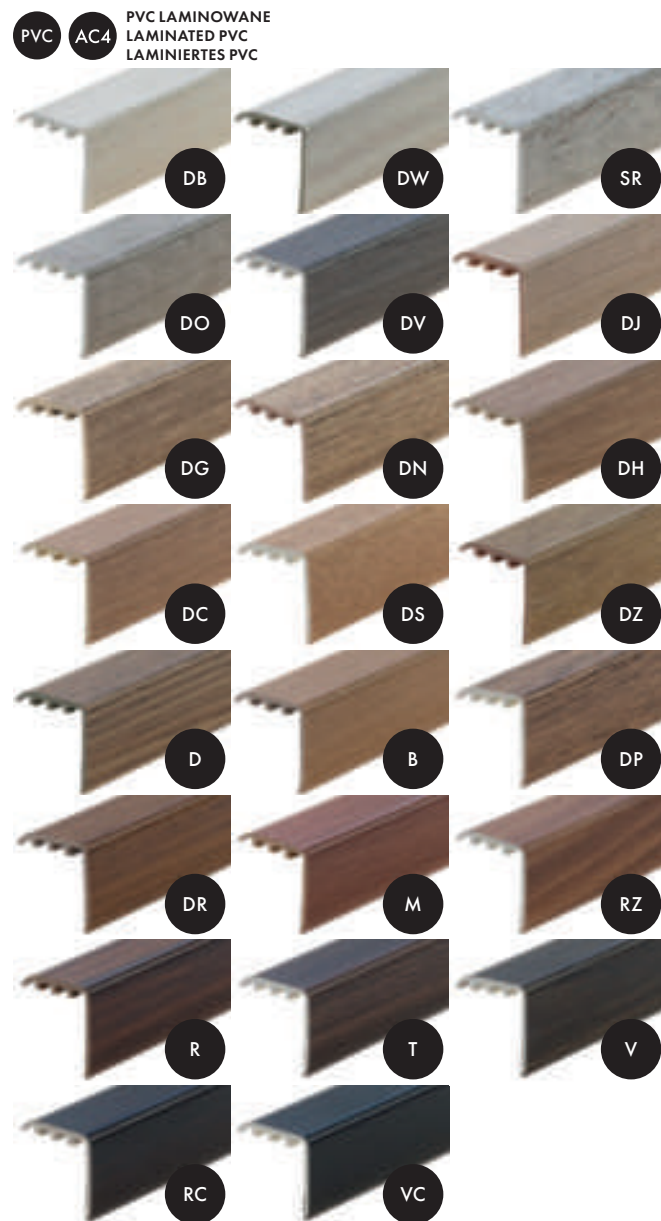
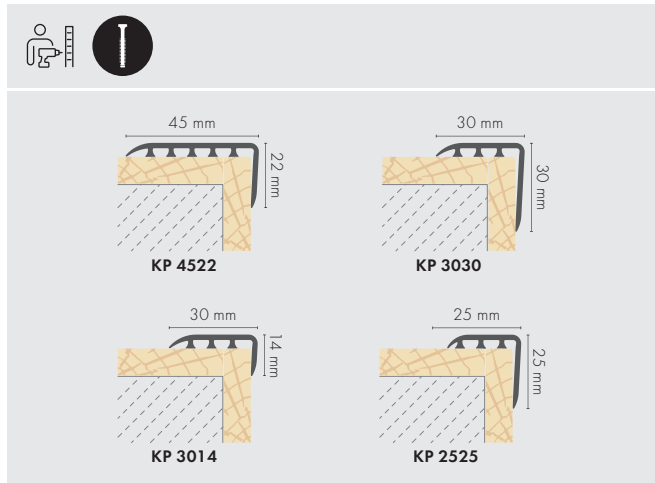

PVC AC4 PVC LAMINOWANE LAMINATED PVC LAMINIERTES PVC

				KP 2525		KP 3014		KP 3030		KP 4522	
DB	PC	OM	0,9 m	896484**	12	897009**	16	896743	10	897269**	10
DB	PC	OM	1,8 m	896613**	10	897139**	10	896873	10	897399**	10
DW	PC	OM	0,9 m	896521**	12	897047**	16	896781	10	897306**	10
DW	PC	OM	1,8 m	896651**	10	897177**	10	896910	10	897436**	10
SR	PC	OM	0,9 m			803918**	16	803956**	10	803987**	10
SR	PC	OM	1,8 m			804427**	10	804434**	10	804441**	10
DO	PC	OM	0,9 m	803994**	12	804014**	16	804052**	10	804076**	10
DO	PC	OM	1,8 m	804458**	10	804465**	10	804472	10	804489**	10
DV	PC	OM	0,9 m	804212***	12					804366**	10
DJ	PC	OM	0,9 m	861499**	12	861574**	16	861697	10	861772**	10
DJ	PC	OM	1,8 m	861505**	10	861581**	10	861703	10	861789**	10
DG	PC	OM	0,9 m	896491**	12	897016**	16	896750	10	897276**	10
DG	PC	OM	1,8 m	896620**	10	897146**	10	896880	10	897405**	10
DN	PC	OM	0,9 m	861512**	12	861598**	16	861710	10	861796**	10
DN	PC	OM	1,8 m	861529**	10	861604**	10	861727	10	861802**	10
DH	PC	OM	0,9 m	804373***	12	804380**	16	804397	10		
DH	PC	OM	1,8 m			804649**	10	804656**	10		
DC	PC	OM	0,9 m	804083***	12	804090**	16	804182**	10	804199**	10
DC	PC	OM	1,8 m			804557**	10	804564**	10	804571**	10
DS	PC	OM	0,9 m			897030**	16	896774	10	897290**	10
DS	PC	OM	1,8 m			897160**	10	896903	10	897429**	10
DZ	PC	OM	0,9 m			861673**	16	861758**	10	861871***	10
DZ	PC	OM	1,8 m			861680**	10	861765	10		
D	PC	OM	0,9 m	896477**	12	896996**	16	896736	10	897252**	10
D	PC	OM	1,8 m	896606**	10	897122**	10	896866	10	897382**	10
B	PC	OM	0,9 m	896460***	12	896989**	16	896729**	10	897245**	10
DP	PC	OM	0,9 m	861536**	12	861659**	16	861734	10	861857**	10
DP	PC	OM	1,8 m	861543**	10	861666**	10	861741	10	861864**	10
DR	PC	OM	0,9 m	896507***	12	897023***	16	896767***	10	897283***	10
DR	PC	OM	1,8 m	896637***	10					897412***	10
M	PC	OM	0,9 m							897313***	10
RZ	PC	OM	0,9 m	896569***	12	897085**	16	896828**	10		
RZ	PC	OM	1,8 m			897214**	10	896958**	10		
R	PC	OM	0,9 m			897061**	16	896804**	10	897320**	10
R	PC	OM	1,8 m			897191**	10	896934**	10	897450**	10
T	PC	OM	0,9 m			897092**	16	896835**	10	897351**	10
T	PC	OM	1,8 m			897221**	10	896965**	10	897481**	10
V	PC	OM	0,9 m	896583**	12	897108**	16	896842**	10	897368**	10
V	PC	OM	1,8 m	896712**	10	897238**	10	896972**	10	897498**	10
RC	PC	OM	0,9 m			897078***	16	896811	10		
RC	PC	OM	1,8 m			897207***	10				
VC	PC	OM	1,8 m					618789***	10		

** Na zamówienie/ On request/ Auf Anfrage *** Outlet



FIX LW 45

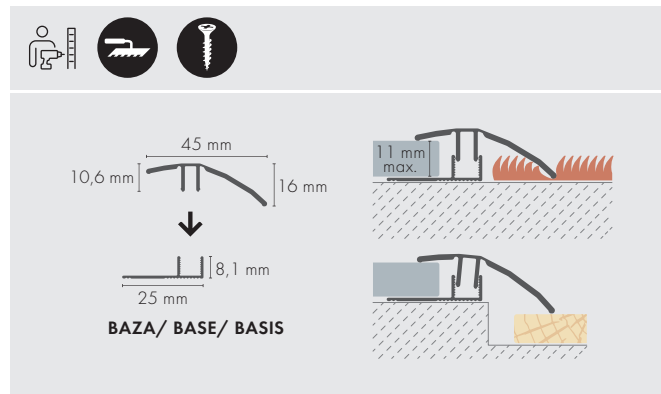

C0	AL	AM	0,9 m	819414	10
C23	AL	AM	0,9 m	819421**	10

** Na zamówienie/ On request/ Auf Anfrage

BAZA/ BASE/ BASIS

N	AL	0,9 m	818875**	60
N	AL	1 m	818882**	60
N	AL	2,7 m	818899**	60

** Na zamówienie/ On request/ Auf Anfrage

AL ALUMINIUM ANODOWANE
ANODIZED ALUMINIUM
ELOXIERTES ALUMINIUM

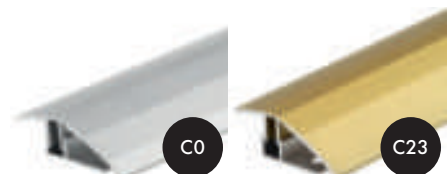

FIX LW 50

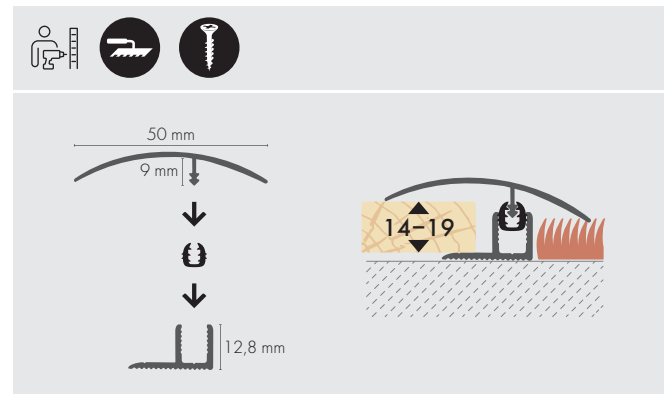

C0	AL	AM	0,9 m	801754	5
C0	AL	AM	2,7 m	825606**	5
C23	AL	AM	0,9 m	801778	5

** Na zamówienie/ On request/ Auf Anfrage

AL ALUMINIUM ANODOWANE
ANODIZED ALUMINIUM
ELOXIERTES ALUMINIUM



ZET O FLEX

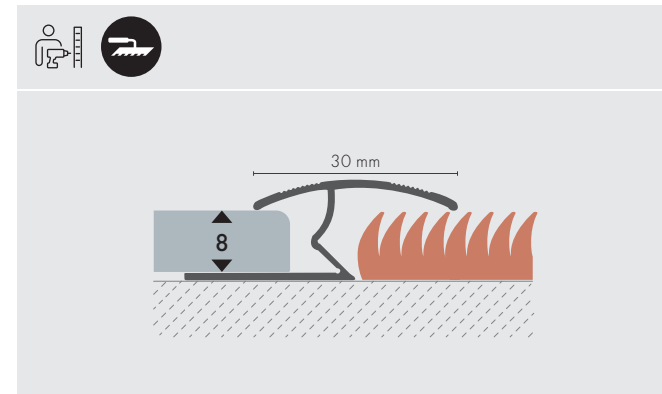

C0	AL	AM	1 m	849305**	10
C0	AL	AM	2 m	849312**	10
C23	AL	AM	1 m	849404**	10
C23	AL	AM	2 m	849411**	10

** Na zamówienie/ On request/ Auf Anfrage

AL ALUMINIUM ANODOWANE
ANODIZED ALUMINIUM
ELOXIERTES ALUMINIUM

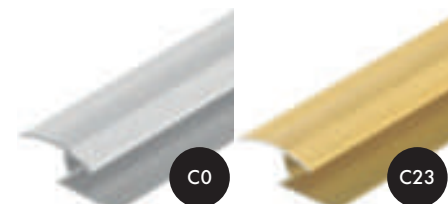

OWAL

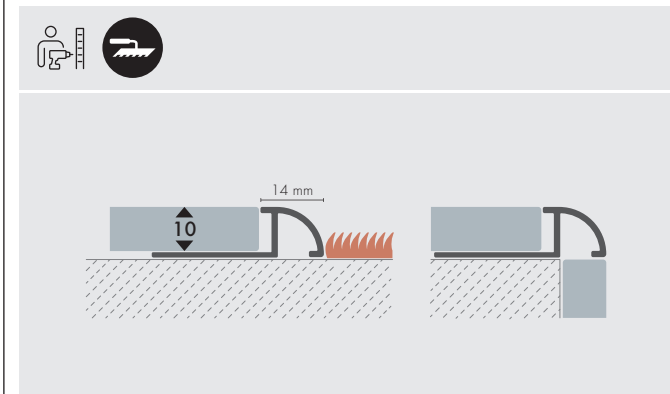

N	AL	S	2 m	801822	10
N	AL	AM	2,5 m	801839	10
P	AL	SP	2 m	801921	10
C0	AL	AM	2,5 m	801860	10
C23	AL	AM	2,5 m	801884	10

AL ALUMINIUM ANODOWANE
ANODIZED ALUMINIUM
ELOXIERTES ALUMINIUM



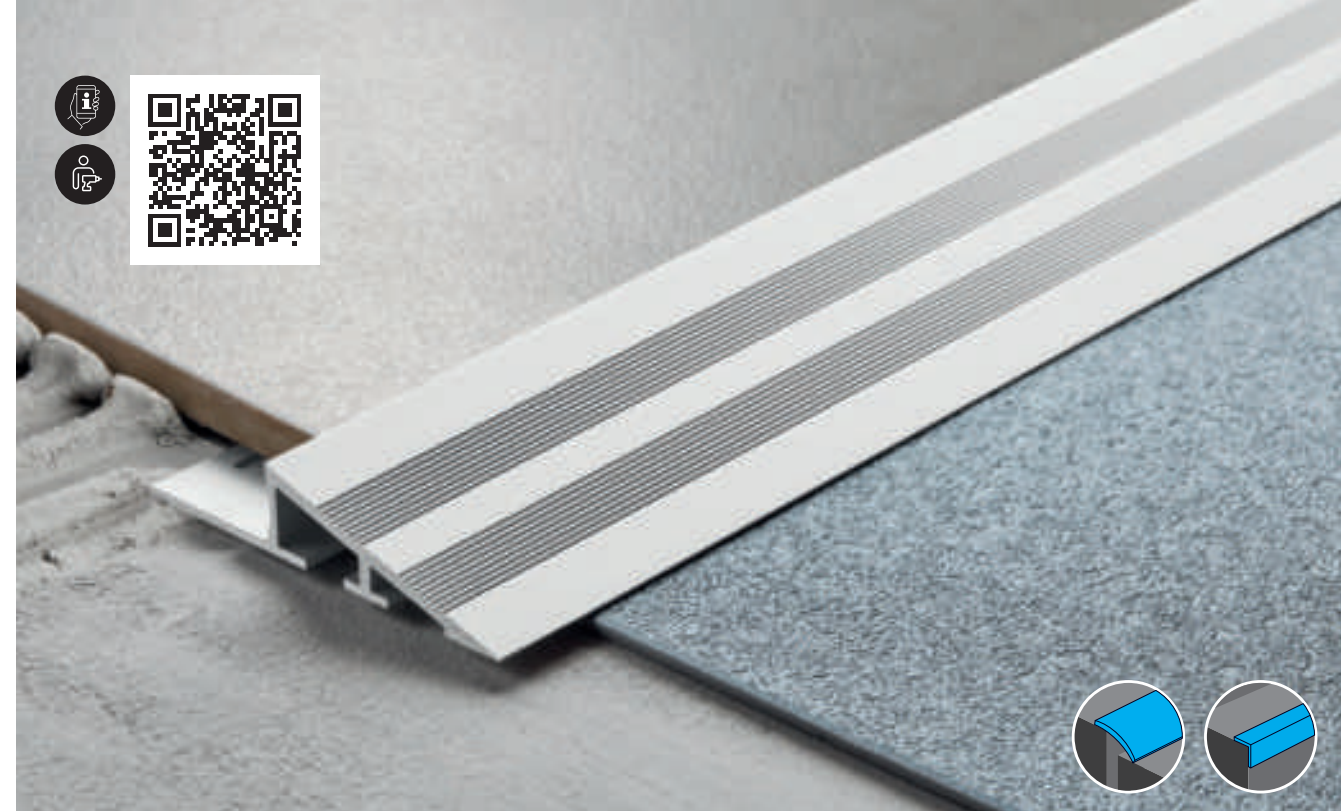
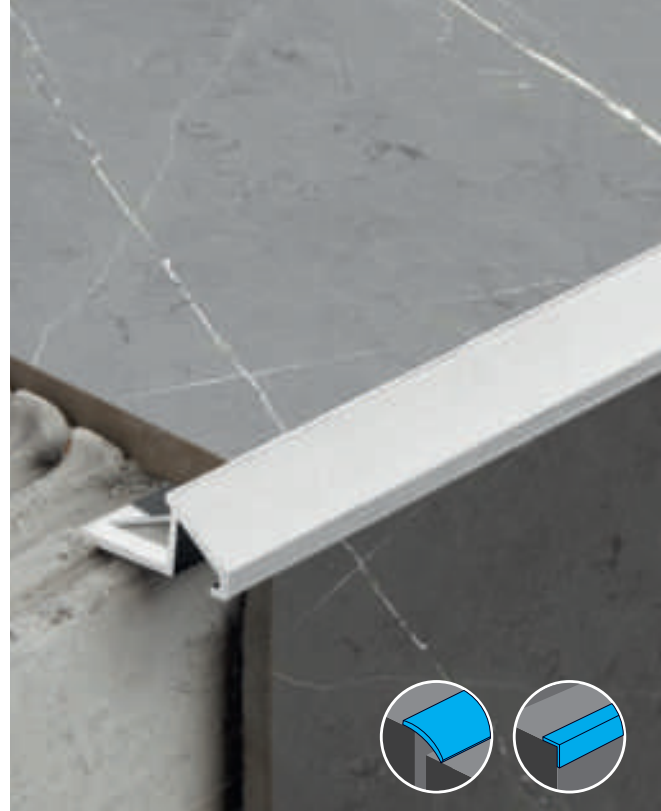

SKOS

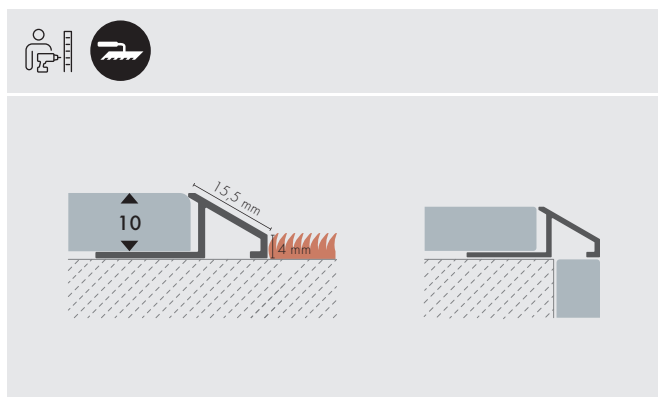

N	AL	S	1 m	801600**	10
N	AL	S	2 m	801624**	10
N	AL	S	2,5 m	801631	10
CO	AL	AM	1 m	801655**	10
CO	AL	AM	2,5 m	801662	10
ZCO	AL	AM	1 m	829123*	10
ZCO	AL	AM	2,5 m	829130*	10
C23	AL	AM	2,5 m	801686**	10
N	MS	S	1 m	811609**	10
N	MS	S	2 m	811623***	10
N	MS	S	2,5 m	811630**	10
P	MS	SP	2,5 m	822537**	10

** Na zamówienie/ On request/ Auf Anfrage *** Outlet

AL ALUMINIUM ANODOWANE
ANODIZED ALUMINIUM
ELOXIERTES ALUMINIUM



MS MOSIĄDZ
BRASS
MESSING



SKOSR

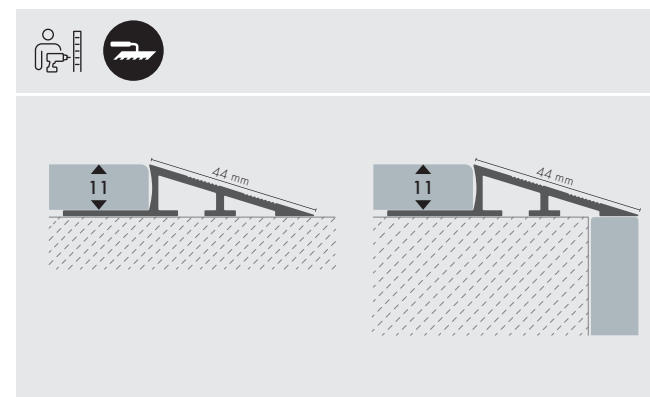

N	AL	S	2,5 m	862977	6
ZCO	AL	AM	2,5 m	829147	6

AL ALUMINIUM ANODOWANE
ANODIZED ALUMINIUM
ELOXIERTES ALUMINIUM



EKSPozyTORY/ DISPLAYS/ SHOP STAND/ VERKAUFSDISPLAYS

9005
RAL



AT-RE-ST-LED12
Profile LED/ LED profiles/ LED-Profil
12 + 3 + 4 x 2 POZYCJI
12 + 3 + 4 x 2 POSITIONS
12 + 3 + 4 x 2 POSITIONEN



AT-RE-ST-M3/OKAP100
OKAP 100
3 POZYCJE
3 POSITIONS
3 POSITIONEN

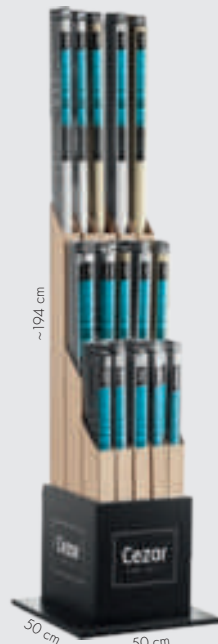

W-RE-S-EX-LW5W1
Ekspozytor listew progowych 5in1
Threshold profile display 5in1
Schwellerleistenanzeige 5in1



AT-RE-ST-G24/MS20
Profile do płytek ceramicznych/
Profiles for tiles/ Profile für Fliesen
24 + 20 POZYCJI
24 + 20 POSITIONS
24 + 20 POSITIONEN



AT-RE-ST-G24
Profile do płytek ceramicznych PVC/
PVC Profiles for tiles/
PVC Profile für Fliesen
24 POZYCJI
24 POSITIONS
24 POSITIONEN

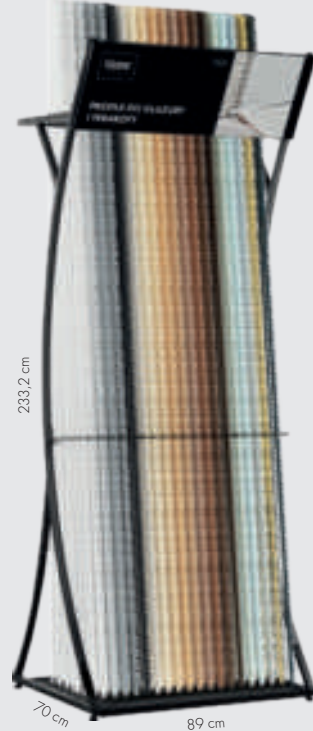

AT-RE-ST-G20/MS20/K
Profile do płytek ceramicznych PVC/
PVC Profiles for tiles/
PVC Profile für Fliesen
20 POZYCJI
20 POSITIONS
20 POSITIONEN



AT-RE-ST-MW21x3
Profile progowe/
Threshold profiles/ Schwelprofil
3 X 21 POZYCJI
3 X 21 POSITIONS
3 X 21 POSITIONEN

SIEDZIBA W EŁKU OUR HEADQUARTERS IN EŁK HAUPTSITZ IN EŁK

ul. Strefowa 2, 19-300 Ełk, POLAND

+48 87 620 99 00

+48 87 620 43 20

cezar@cezar.eu

DZIAŁ OBSŁUGI KLIENTA/ CUSTOMER SERVICE/ KUNDENDIENST

1

KAMILA CZEKAŁA

Specjalista ds. Sprzedaży i obsługi eksportu
Sales and Export specialist
Spezialist für Verkauf und Abwicklung im Export

+48 87 620 99 91

+48 515 055 760

k.czekala@cezar.eu

2

EDYTA KORCZ-FADROWSKA

Specjalista ds. Sprzedaży i obsługi eksportu
Sales and Export specialist
Spezialist für Verkauf und Abwicklung im Export

+48 87 620 99 05

+48 510 233 012

e.korcz@cezar.eu

3

MACIEJ NOWAKOWSKI

Specjalista ds. Sprzedaży i obsługi eksportu
Sales and Export specialist
Spezialist für Verkauf und Abwicklung im Export

+48 87 620 99 09

+48 513 039 638

m.nowakowski@cezar.eu

PRZEDSTAWICIELE HANDLOWI SALES REPRESENTATIVES VERTRIEB

JAROSŁAW KALISZUK

Kierownik Sprzedaży - Polska
Sales Area Manager - Poland
Verkaufsleiter - Polen

+48 510 233 008

j.kaliszuk@cezar.eu

SIECI HANDLOWE DIY RETAILERS HANDELSNETZE

RADOSŁAW SAŁATA

Dyrektor Sprzedaży - Polska
Sales Area Director - Poland
Verkaufsdirektor - Polen

+48 515 055 732

r.salata@cezar.eu

OBSŁUGA INWESTYCJI INVESTMENT SUPPORT INVESTITIONSBETREUUNG

WOJCIECH SIEMASZKO

Kierownik Sprzedaży ds. rynku inwestycyjnego
Investment Market Sales Manager
Verkaufsleiter für den Investitionsmarkt

+48 505 334 337

w.siemaszko@cezar.eu

EKSPORT EXPORT EXPORT

RENATA KOZŁOWSKA

Dyrektor Eksportu
Export Director
Exporthändler

+48 87 620 97 09

+48 501 329 631

r.kozlowska@cezar.eu

FR ENG

INNA POLYAKOVA

Zastępca Dyrektora Eksportu
Deputy Export Director
Stellvertretender Exporthändler

+48 87 620 99 16

+48 695 830 010

i.polyakova@cezar.eu

ENG RUS



Niniejszy katalog nie stanowi oferty w rozumieniu kodeksu handlowego. Prezentowane kolory mogą nieznacznie odbiegać od rzeczywistości z uwagi na techniczne uwarunkowania technologii druku. Cezar zastrzega sobie prawo do zmian. Wydanie grudzień 2024.

This catalogue does not constitute an offer within the meaning of the Commercial Code. The colours shown on illustrations may deviate slightly from reality due to the technical conditions of the printing technology. Cezar reserves the right to make changes. December 2024 Edition.

Dieser Katalog stellt kein Angebot im Sinne des Handelsgesetzbuches dar. Die dargestellten Farben können aufgrund der technischen Gegebenheiten der Drucktechnik leicht von der Realität abweichen. Cezar behält sich das Recht vor, Änderungen vorzunehmen. Ausgabe Dezember 2024.



PERFECTION IN DETAILS

1958
since

ul. Strefowa 2
19-300 Elk, Polska
+48 87 620 99 00
+48 87 620 43 20
cezar@cezar.eu
www.cezar.eu

